

EXACTECH | EXTREMITIES

Operative Technique



equinox[®]

Platform
Shoulder System



TABLE OF CONTENTS

INTRODUCTION.....	3	Step 3: Humeral Preparation	37
Primary Shoulder	3	Humeral Head Resection	37
Reverse Shoulder	3	Anatomic Cutting Guide:The Equinoxe	37
OPERATIVE TECHNIQUE OVERVIEW.....	4	Reaming the Humeral Shaft.....	39
Pre-Operative Planning/Patient Positioning	7	Broaching the Humeral Shaft.....	40
Step 1: Patient Positioning.....	7	Inserting the Humeral Stem Trial.....	41
Step 2: Surgical Approach	7	Humeral Stem Protector	41
DETAILED OPERATIVE TECHNIQUE	7	Step 4: Preparing The Glenoid.....	42
Primary Shoulder	7	Glenoid Exposure.....	42
Step 3: Humeral Preparation	8	Reaming the Glenoid	42
Humeral Head Resection	8	Pilot-Tip Reamers.....	44
Anatomic Cutting Guide	8	Cannulated Reamers.....	46
Evaluate Resected Head Size.....	10	Drill Cage Hole through Drill Guide.....	47
Reaming the Humeral Shaft.....	10	Bone Graft for Glenoid Plate	48
Broaching the Humeral Shaft.....	11	Implanting the Glenoid Plate.....	48
Humeral Stem Insertion.....	12	Inserting the Glensphere Trial	51
Cementing the Press-Fit Prosthesis	12	Step 5: Trialing The Humeral Adapter Tray And Liner.....	56
Humeral Stem Protector	13	Step 6: Inserting The Final Implants.....	58
Step 4: Preparing the Glenoid	14	Step 7: Deltopectoral Closure.....	61
Glenoid Exposure.....	14	Step 8: Superolateral Closure.....	62
Assessing Glenoid Version	14	Glensphere Removal	62
Choosing the Glenoid	14	Post-Operative Rehabilitation	62
Reaming the Glenoid	16	IMPLANT LISTING	64
Preparing the Glenoid	18	INSTRUMENT LISTING	66
Preparing the Cemented Pegged and Cage		SYSTEM SPECIFICATIONS	74
Glenoid.....	20	INDICATIONS FOR USE	76
Preparing the Cemented Keeled Glenoid.....	22	Primary & Reverse Shoulder System	76
Cementing the Pegged And Keeled Glenoids	23	Indications.....	76
Cementing the Cage Glenoid	24	Contraindications	76
Removing the Cage Glenoid.....	25	REFERENCES	80
Step 5: Head Positioning.....	26		
Replicator Plate Selection.....	26		
Attaching the Replicator Plate	26		
Dialing in the Head Position	27		
Assessing Range of Motion	28		
Torque Defining Screw	29		
Impacting the Humeral Head	30		
Revising a Hemi to a TSA.....	30		
Step 6: Closure	31		
Post-Operative Rehabilitation	32		
OPERATIVE TECHNIQUE OVERVIEW.....	33		
Reverse Shoulder	33		
DETAILED OPERATIVE TECHNIQUE	36		
Reverse Shoulder	36		
Step 1: Patient Positioning.....	36		
Step 2: Surgical Approach	36		
Deltopectoral Approach	36		
Superolateral Approach.....	36		

EQUINOXE® PLATFORM SHOULDER SYSTEM

OPERATIVE TECHNIQUE

INTRODUCTION

The Equinoxe® Shoulder System redefines “anatomical.” The platform primary stem is designed to allow independent adjustability of all four anatomic parameters in situ. The reverse shoulder is designed to minimize both scapular notching and torque on the glenoid while seamlessly integrating with the primary and platform fracture stems. The platform fracture stem’s offset anterior-lateral fin and asymmetric tuberosity beds define the next generation in complex fracture reconstruction. The platform nature of the Equinoxe primary and fracture stem allows the surgeon to have intra-operative flexibility to choose between a hemiarthroplasty, primary total shoulder or reverse total shoulder and seamlessly convert to a reverse should a revision become necessary.

Thank you for considering the Equinoxe Shoulder System. We began the Equinoxe product development process by identifying concerns our team had with shoulder replacement, including the well-documented challenges and complications surgeons have experienced with reverse shoulders. Our goal was to develop solutions to those concerns, and we believe the Equinoxe System significantly improves the surgeon’s ability to precisely replicate the patient’s anatomy. In general, we sought the following improvements:

PRIMARY SHOULDER

Patented Replicator Plate. Provides *in situ* adjustment ($\pm 7.5^\circ$) for both version and neck angle without the need for trials or back table assembly.

Anatomical Glenoid Options. Designed as both pegged and keeled components with two radii of curvature, which allows the components to be paired with any size humeral head while maintaining the optimal radial mismatch. Posterior augment glenoids are designed to preserve bone in challenging glenoids to help maintain the native joint line.

Intra-operative Flexibility. Allows surgeons to convert from a total shoulder to a reverse without stem removal.

REVERSE SHOULDER

Minimize Scapular Notching. The reverse lateralizes the humerus by using larger glenospheres and decreasing the humeral neck angle. The innovative glenoid baseplate design has a built-in offset that distally shifts the glenosphere to a position that prevents humeral liner impingement on the inferior glenoid.^{1,2}

Enhance Glenoid Fixation. The press-fit bone cage is designed to provide strong initial fixation, while the baseplate provides up to 30 degrees of angular variability to ensure optimal compression screw placement and purchase—even in poor quality bone.³

Revision Friendly. The six screw holes provide optimal screw fixation, even when revising a pegged or keeled glenoid to a reverse shoulder. A wide range of augmented glenoid baseplates are available to address various types of glenoid wear.

Bone Conservation. The humeral reverse components do not require reaming of the proximal humerus, so the size of the glenosphere is no longer limited by the corresponding humeral cup size that will fit in the proximal humerus.

We hope that you come to agree, based on your experiences with the Equinoxe Shoulder System in the O.R., that we have accomplished our goal.

Finally, while we have taken a comprehensive approach to this operative technique, we would be remiss if we failed to make it clear that shoulder replacements are challenging procedures and should be performed by surgeons with significant experience. If you are new to primary or reverse shoulders, please consider observing a shoulder specialist, watching a shoulder surgical DVD, performing a sawbone and/or implanting in a cadaver to ensure you are comfortable with the surgical technique. We would be happy to facilitate any aspect of this training to ensure success in the O.R. for the surgeon and the staff.

Respectfully,

Lynn A. Crosby, MD
Medical College of Georgia

Pierre-Henri Flurin, MD
Surgical Clinic of Bordeaux, Merignac (France)

Sean G. Grey, MD
University of Cincinnati School of Medicine

Thomas W. Wright, MD
University of Florida

Joseph D. Zuckerman, MD
NYU Hospital for Joint Diseases

OPERATIVE TECHNIQUE OVERVIEW

PRIMARY SHOULDER

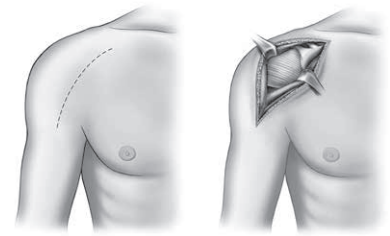

Figure A
Incision and Exposure



Figure B
Resect the Humeral Head

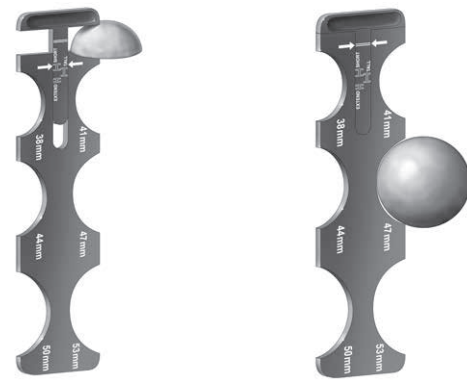

Figure C
Evaluate Height and Diameter of Resected Head



Figure D
Ream Humeral Shaft



Figure E
Broach Humeral Shaft



Figure F
Insert Press-Fit Stem



Figure G
Insert Stem Protector

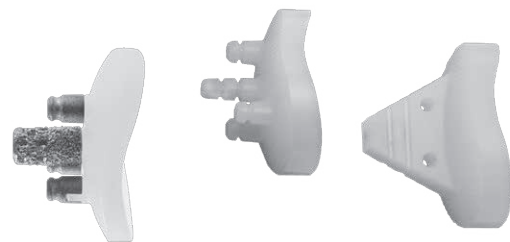

Figure H
Choose Glenoid



Figure I
Pilot-Tip Option: Drill Center Hole
and Ream the Glenoid

OPERATIVE TECHNIQUE OVERVIEW

PRIMARY SHOULDER



Figure J
Cannulated Option: Insert K-wire, Ream and then
Drill Center Hole over K-wire



Figure K
Prepare Pegged Glenoid



Figure L
Prepare Keeled Glenoid



Figure M
Implant Trial Glenoid

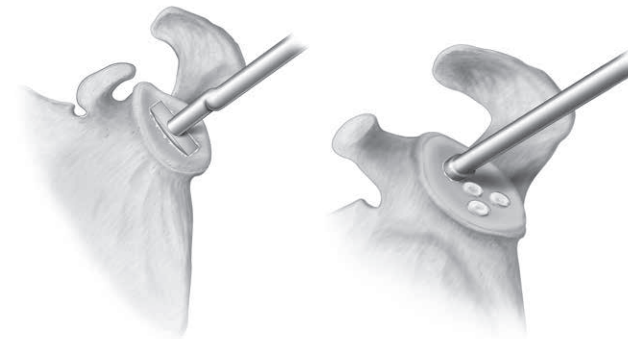

Figure N
Pressurize the Cement



Figure O
Cement and Impact Final Glenoid

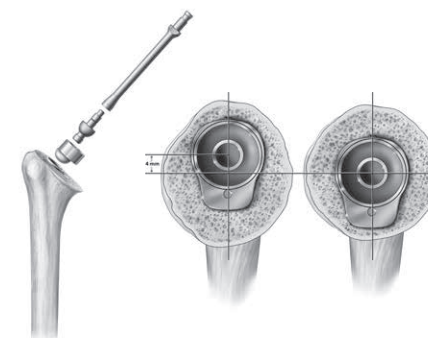

Figure P
Select and Attach Replicator Plate



Figure Q

Cover Resected Surface with Dual Offsets



Figure R

Assess Range of Motion



Figure S

Disengage Superior Portion of Screw



Figure T

Impact Final Humeral Head

PRE-OPERATIVE PLANNING/PATIENT POSITIONING

After a careful history and physical examination, radiographs should be obtained to assess glenohumeral joint space narrowing, osseous deformities and glenoid wear. The following three radiographic views should be obtained: 1) a true A/P view of the glenohumeral joint (30 degrees external oblique), 2) a scapular lateral view and 3) an axillary view.

In patients with osteoarthritis, varying amounts of posterior glenoid wear (with posterior subluxation of the humeral head) are common. If significant glenoid wear is a concern, a CT scan may be helpful to further define the bony anatomy.

Rotator cuff tears are relatively uncommon in patients with osteoarthritis. The status of the rotator cuff can be determined at the time of surgery. For this reason, MRI or ultrasonography imaging is not routinely performed, though the decision is based upon surgeon preference.

To aid in pre-operative planning, radiographic templates are available for the humeral stems, humeral heads and glenoids to approximate the required sizes.

STEP 1: PATIENT POSITIONING

The patient should be placed on an operating table in a supine position. The head of the operating table should be elevated approximately 30 degrees in a modified beach chair position. A small bolster should be placed laterally behind the involved shoulder. The patient should be moved to the side of the table so that the upper extremity can be placed into maximum extension without obstruction by the operating table. Alternatively, a Captain's chair or similar positioning device can be used for proper patient positioning. The patient should be secured to the operating table to minimize any changes in position intra-operatively.

Once the patient is secure, the extremity is examined to assess the range of motion, with particular attention to external rotation with the arm at the side. If external rotation is restricted (i.e., internal rotation contracture) the need for more extensive subscapularis mobilization or lengthening procedures may be necessary. The entire upper extremity should be prepped and draped to allow complete access to the operative area and full mobility during the procedure.

STEP 2: SURGICAL APPROACH

An anterior deltopectoral incision is made beginning inferior to the clavicle and passing over the coracoid process and extending distally toward the deltoid insertion. Medial and lateral subcutaneous flaps are created, and the deltopectoral interval is identified.

A thin fat stripe is usually located over the cephalic vein. The interval is usually developed medial to the cephalic vein; the interval can also be developed laterally depending on the surgeon's preference. Branches of the cephalic vein on the approach side are cauterized, and the interval is developed inferior to superior to expose the clavipectoral fascia.

The advantage of retracting the cephalic vein with the deltoid is that the majority of the branches come from the deltoid. The disadvantage is the vein is more exposed to injury from the retractor as it crosses the superior aspect of the interval.

The subdeltoid space is mobilized with a blunt elevator. The clavipectoral fascia is incised longitudinally up to the coracoacromial ligament (which is spared), and the conjoined tendon is mobilized. A self-retaining retractor is placed with care to avoid excessive traction on the conjoined tendon. The coracoacromial ligament is identified and the subacromial space is mobilized with a blunt elevator. The subscapularis tendon insertion on the lesser tuberosity is identified along with the rotator interval. The anterior humeral circumflex vessels along the inferior border of the subscapularis muscle, the "three sisters," are cauterized extensively, and the biceps tendon is palpated in its groove. The subscapularis tendon and the capsule are tenotomized 1cm medial to the lesser tuberosity and tagged with #1 sutures.

An alternative approach is to elevate the subscapularis directly off of bone or elevate its insertion with a thin wafer of bone (1-2mm thick) using an osteotome. The choice is based primarily on surgeon preference.

The rotator interval is divided in a lateral to medial direction up to the superior glenoid rim. With the humerus extended, adducted and externally rotated, the capsule is carefully dissected off the inferior humeral neck, protecting the axillary nerve inferiorly with a small blunt retractor placed just inferior to the capsule. The capsular releases should be performed to allow 90 degrees of external rotation. The self-retaining retractor is then repositioned to retract the subscapularis. At this point, the humeral head can be dislocated.

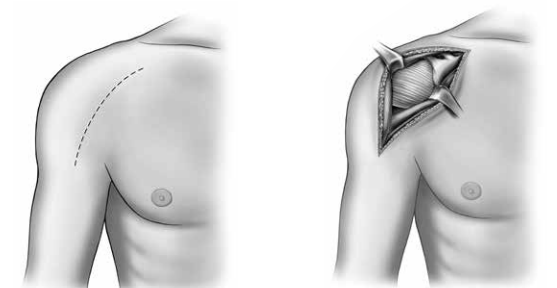

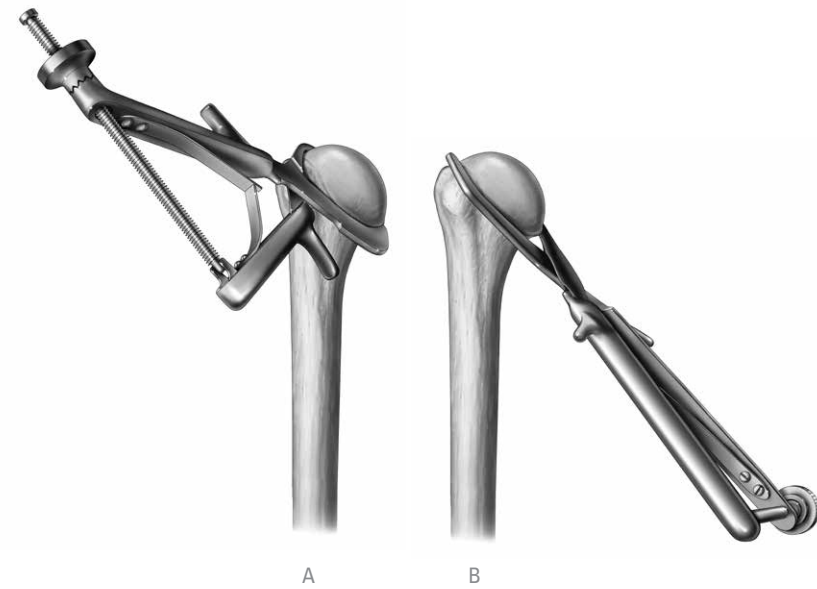

Figure 1
Anatomic Cutting Guide

STEP 3: HUMERAL PREPARATION

Humeral Head Resection

Prior to the humeral head resection, all osteophytes should be removed using a rongeur. Doing so will properly expose the anatomic humeral neck; anatomic replication is facilitated by an accurate resection along the anatomic neck. Three resection options are available and should be selected based upon surgeon preference.

Anatomic Cutting Guide

The Equinox **Anatomic Cutting Guide** enables the surgeon to accurately resect the humeral head along the anatomic neck without the use of intramedullary or extramedullary fixturing devices (*Figure 1*). The jaws encircle the humeral head along the anatomic neck, acting as a cutting surface.

Cutting from the inferior to superior (*Figure 1a*), the thin jaw of the Anatomic Cutting Guide should slide between the bone and the superior cuff. The wide jaw should be in direct contact with the medial portion of the anatomic neck. Alternatively, an anterior-posterior cutting approach (*Figure 1b*) can be used with the thin jaw encircling the posterior side of the anatomic neck and the cutting jaw positioned on the anterior side. Once the guide is in position, it is secured using the threaded knob. To ensure the device does not move, hold the handle while performing the osteotomy. To protect the rotator cuff, the saw blade should not pass superior or posterior to the thin jaw.



Figure 2
Fixed Angle Cutting Guide

Note: Removing the osteophytes is imperative in order to visualize the anatomic neck, but it also improves the bite obtained by the teeth on the cutting guide.

Free Hand: Identify the anatomic neck and resect the head using a microsagittal saw.

Fixed Angle (132.5 degrees) Guide: Though this method is not based upon the patient's anatomy, we have provided a **Fixed Angle Cutting Guide** for surgeons who prefer this method (*Figure 2*). Three options are available for the guide: 1) the surgeon may attach the guide to a handle, which aligns with the forearm for 20 degrees of retroversion,

2) use .062 K-wires to secure it to the bone or

3) use the cutting surface to mark the resection line with a bovie and then use the free hand method.

With this method, the superior portion of the resection should be just medial to the rotator cuff insertion. The amount of retroversion (usually 20-40 degrees) should be determined by positioning the humerus in external rotation before the resection is made.



Figure 3
Humeral Head Sizer

Head Size (mm)	38	41	44	47	50	53
Glenoid Curvature	Alpha			Beta		

Table 1
Relationship between Humeral Head Diameter and Glenoid Curvature

Evaluate Resected Head Size

After resecting the humeral head, use the **Humeral Head Sizer** to estimate both the head's diameter (circumferentially) and height in order to determine the probable size of the modular humeral head (*Figure 3*). **The head diameter will determine what sized glenoid will be used (for TSA), as described in Table 1.**

Reaming the Humeral Shaft

The smallest **Reamer** (7mm) has a sharp tip to facilitate the initial entry into the IM canal (*Figure 4*). The entry point is made just posterior to the bicipital groove and at the junction of the middle and upper thirds of the resected humeral surface. The canal should be sequentially reamed until endosteal cortical contact is obtained. It is imperative that the Reamer be inserted into the canal to the appropriate depth as indicated by the depth markers; **reaming prepares the canal for the distal diameter of the stem and determines the final diameter of the definitive stem.** There is no need for forceful reaming. If there is difficulty fully inserting a reamer, the broach and implant selected should be the size of the last reamer that was completely seated. If there is any concern about the size of the implant to use, the smaller alternative should be selected since the stem can be cemented in place.



Figure 4
Insert Reamer

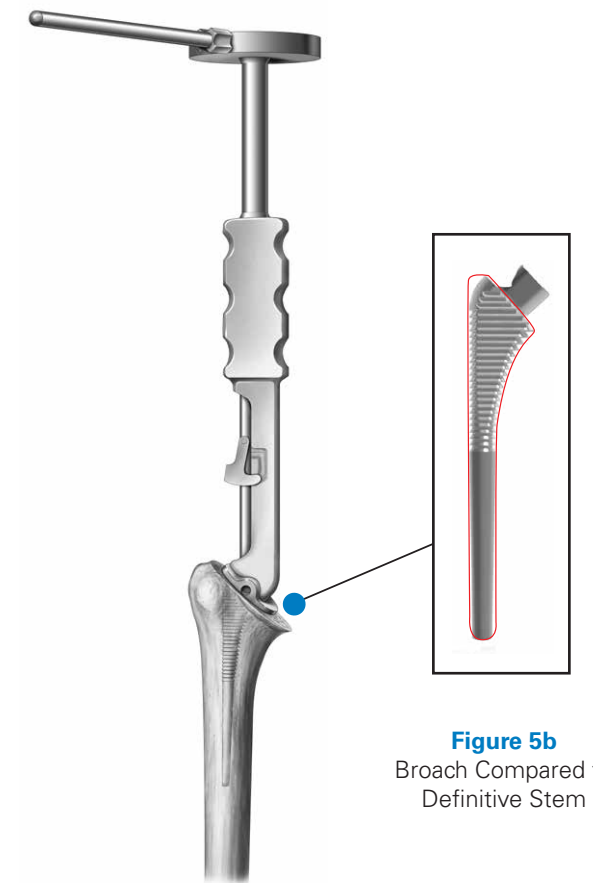

Figure 5
Insert Broach

Figure 5b
Broach Compared to Definitive Stem

Note: To ensure the adequate depth is achieved, ream until the depth marker is no longer visible.

Note: Since the Reamer is the only instrument that prepares the distal canal, do not attempt to implant a stem that is larger than the largest reamer fully seated.

Broaching the Humeral Shaft

After the canal has been reamed, attach the smallest Broach (7mm) to the **Modular Broach Handle** as illustrated (*Figure 5*). The Broach should be inserted into the canal at a version consistent with that of the cut surface (i.e. the broach collar should be flush with the resected surface). The canal should be sequentially broached until the size of the broach matches that of the final reamer. Each Broach should be impacted until

contact is made between the resected bone surface and the broach collar. The Broach should not be countersunk and only the strike surface should be used for impaction.

As a visual check to assess version, the **Retroversion Handle** can be attached to the broach handle ("L" and "R" indicate appropriate side) and lined up with the patient's forearm (assuming the patient has a stable elbow). The Retroversion Handle indicates 20 degrees retroversion when aligned with the forearm.

Note: The Broach is undersized distally because the reamer prepares the distal canal. This enables the surgeon to create a cement mantle by upsizing the Broach in cases where a proximal cement mantle is desired (*Figure 5b*).



Figure 6
Insert Humeral Stem

Humeral Stem Insertion

One unique advantage of the Equinox primary shoulder system is that it does not require stem trialing. Once the humeral canal is prepared, the implant is ready to be inserted into the canal. The implant (**having the same distal diameter as that of the final reamer**) is threaded to the **Primary Stem Inserter** (Figure 6). Be sure to align the dimple on the inserter with the divot in the stem.

The broaches are undersized by 1mm (total diametrical press-fit 0.5mm per side) to ensure adequate press-fit; therefore, impaction is necessary to insert the stem into the canal. For this reason, it is important that the stem be completely threaded to the Stem Inserter prior to impaction to prevent damage to the threads. Use the **Mallet** to impact the Stem Inserter until the superior face of the stem is at the level of

the resected surface (only the strike surface should be used for impaction).

As a visual check to assess version, the Retroversion Handle can be attached to the Stem Inserter in the same manner described above.

Note: *If a tendon-to-bone repair is utilized, prepare the drill holes in the proximal humerus to facilitate the subscapularis repair prior to humeral stem insertion.*

Cementing the Press-Fit Prosthesis

The press-fit Equinox humeral stem was designed with several features that optimize a cementless application. However, the stem has features that enable it to be cemented if desired. In this situation, a stem one size smaller in diameter (than the broach size) would provide a minimum



Figure 7
Stem Protector

1mm cement mantle proximally and a minimum 2mm distally.

In cases where an adequate press-fit was not achieved, the surgeon has two options. A minimized cement technique could be employed whereby a small amount of cement is placed in the proximal canal and, for example, an 11mm stem is cemented in a humerus that has been reamed to an 11 and broached to an 11. Alternatively, in this same scenario, the surgeon could broach to a 13 to create room for a more robust proximal cement mantle and then cement the 11mm stem.

The use of a cement restrictor is based on personal preference; however, an appropriately sized cement restrictor will improve distribution. Formal cement pressurization is avoided to decrease the possibility of humeral shaft fracture. The intramedullary canal should then be packed with a

sponge to obtain adequate drying before cementing. Once the canal is prepared, the cement is mixed and injected into the canal.

Humeral Stem Protector

If the procedure requires a glenoid implant, place the humeral **Stem Protector** into the proximal portion of the implanted stem to protect the resected surface during glenoid preparation (Figure 7). If a glenoid is not being implanted, Step 4 is omitted.

Note: *The Stem Protector is offset so it can be rotated to ensure the best possible coverage. It is important for it to reach cortical bone so the cancellous bone is not damaged during glenoid exposure. A smaller option is also included.*

STEP 4: PREPARING THE GLENOID

Glenoid Exposure

Retractors are provided to aid in glenoid exposure. A **Posterior Glenoid Retractor** should be used to displace the proximal humerus posteriorly. The **Single Point Glenoid Retractor** is then placed anteriorly along the glenoid neck. **Hohmann Retractors** are placed superiorly and inferiorly around the glenoid.

The glenoid labrum is excised and an anterior and inferior capsular release is performed both for exposure and soft tissue mobilization. A formal posterior capsular release is only performed if adequate glenoid exposure cannot be obtained or if limitation of internal rotation is identified as a significant problem.

Some surgeons prefer to resect the biceps insertion and perform a biceps tenodesis. Biceps release and tenodesis will also enhance glenoid exposure. At this point, the degree and location of glenoid erosion can be visualized.

Note: Some key steps to adequate glenoid exposure are as follows:

- 1) Fully mobilize subdeltoid space
- 2) Release inferior capsule completely off the humerus by externally rotating humerus
- 3) Release anterior capsule and subscapularis from glenoid
- 4) Excise labrum and release anterior and inferior capsule (protect axillary nerve)
- 5) Resect adequate amount of humerus
- 6) Stretch posterior capsule with humeral head retractor pushing humerus posterior to the glenoid
- 7) Biceps release with excision of superior labrum will also assist with glenoid exposure
- 8) If exposure is not adequate after steps 1-7, release posterior inferior capsule and triceps origin (must isolate and retract axillary nerve for this procedure)
- 9) If still poor exposure (very rare), then a posterior capsule release should be performed.

Assessing Glenoid Version

Glenoid wear requires special consideration. With increasing posterior glenoid erosion, posterior humeral head subluxation occurs with secondary stretching of the posterior capsule. Options to treat this asymmetric wear include, most commonly, reaming eccentrically to lower the high (non-worn) side or using augmented glenoids to build up the worn side. See the Posterior Augment Glenoid Operative Technique (718-01-32) for additional information. In very severe cases, bone grafting to elevate the low (worn) side may also be another option. In Step 5, the surgeon will have the opportunity to modify humeral head version by up to 7.5 degrees if additional stability is required.

Occasionally, there may be significant symmetric (central) wear, which is more common in inflammatory arthritis. In these cases, the remaining glenoid vault should be assessed for its capacity to support a glenoid component. A **Keeled Glenoid** component can be inserted in the majority of cases of moderate central wear. If a **Pegged Glenoid** component is used, perforation by one or more of the pegs may occur. Although generally acceptable, it should be avoided when possible.

If the glenoid bone is inadequate (an uncommon occurrence), hemiarthroplasty should be performed with glenoid shaping to provide a concave surface for the humeral head.

Choosing the Glenoid

The Equinoxe System provides Cemented Keeled, Pegged, Cage and Posterior Augment Glenoid options (*Figure 8*). The specific glenoid chosen should be based on surgeon preference and the patient's anatomy. For severely eroded glenoids, refer to #718-01-32 for use of the posterior augment glenoid. For the medium and large Keeled, Pegged and Cage Glenoids, two articular curvatures are provided (alpha and beta) so that these sized glenoids can be matched with any size humeral head component (38mm - 53mm) while at the same time obtaining an optimal radial mismatch (average 5.5mm). This is accomplished by choosing an alpha or beta glenoid based upon the humeral head diameter. The small Keeled and Pegged Glenoids are only provided in the alpha curvature (*Table 2*). The extra large Pegged Glenoid is only provided in the beta curvature.



Figure 8
Equinoxe® Cage, Pegged and Keeled Glenoids

	Humeral Head Diameter					
	38mm	41mm	44mm	47mm	50mm	53mm
Small, Medium and Large α UHMWPE Keel and UHMWPE Peg and Cage Glenoids	✓	✓	✓			
Medium and Large β UHMWPE Keel				✓	✓	✓
Medium, Large and Extra Large β UHMWPE Peg and Cage Glenoids				✓	✓	✓

Table 2
Glenoid/Humeral Head Pairings



Figure 9a
Pilot-Tip Reamer



Figure 9b
Cannulated Reamer

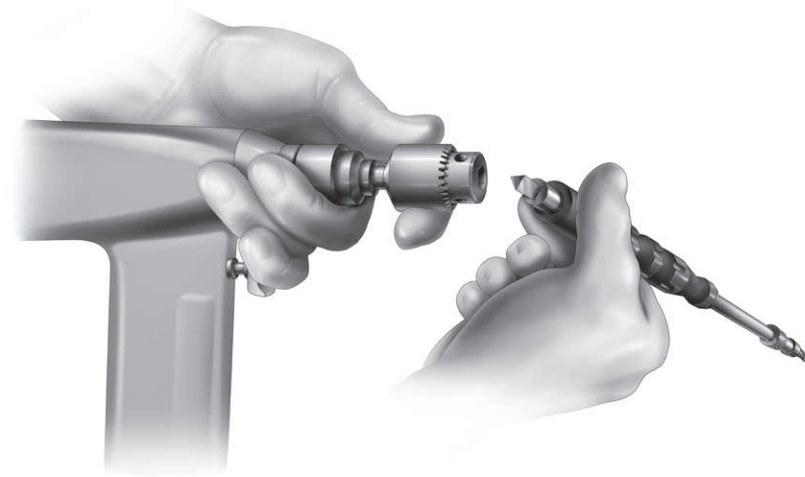

Figure 10
Connect Modular Glenoid Driver

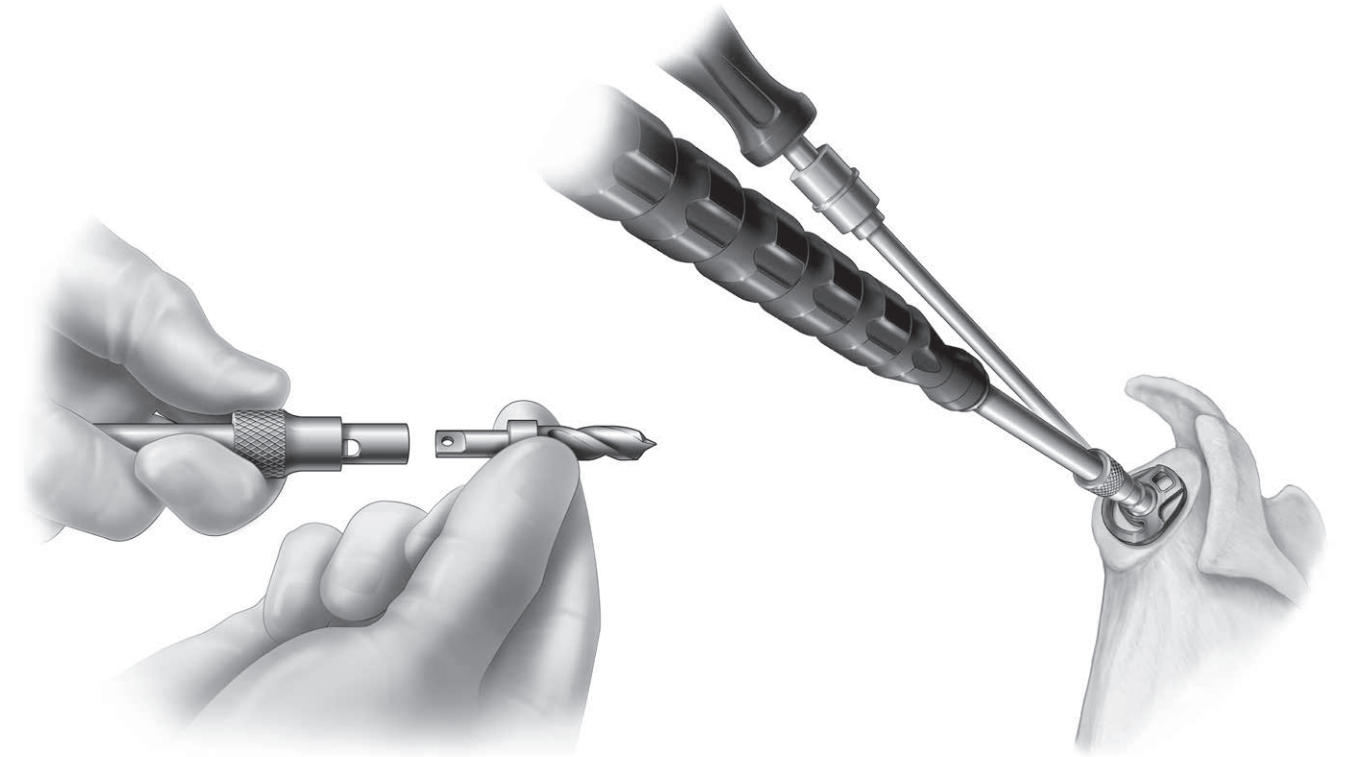

Figure 11
Connect Modular Center Peg/Keel Drill to
Glenoid Driver

Figure 12
Drill the Center Hole

Reaming the Glenoid

The Equinox primary system provides two options to ream the glenoid: 1) **Pilot-Tip** and 2) **Cannulated Reamers** (Figure 9a and 9b). Pilot-Tip Reamers have a rounded-pilot, which provides the surgeon greater angular adjustability and thereby facilitates eccentric reaming. Cannulated Reamers rotate about a 0.079 inch K-wire and provide the surgeon maximum precision.

Regardless of the reaming option, the first step is to identify the center of the glenoid (the point where the superior/inferior and anterior/posterior glenoid axes intersect); ensure that all glenoid osteophytes have been removed so that the true center of the glenoid can be accurately identified. The

diameter of each sized glenoid reamer corresponds to the height of each size glenoid implant; therefore, sequentially ream the glenoid until the reamer completely conforms the articular surface of the glenoid.

Note: The Modular Glenoid Driver is connected to the powered drill/hand piece via a Jacobs Chuck (Figure 10).

If using the Pilot-Tip Reamers, connect the **Modular Center Peg/Keel Drill** to the **Modular Driver** and drill the center hole through the **Center Hole Drill Guide** (Figures 11 and 12).

Size	Color of Reamer and Trials
S	Blue
M	Green
L	Purple
XL	Orange

Table 3
Color-coded Reamers and Trials



Figure 13
Connect Modular Primary Pilot-Tip Reamer to Glenoid Driver

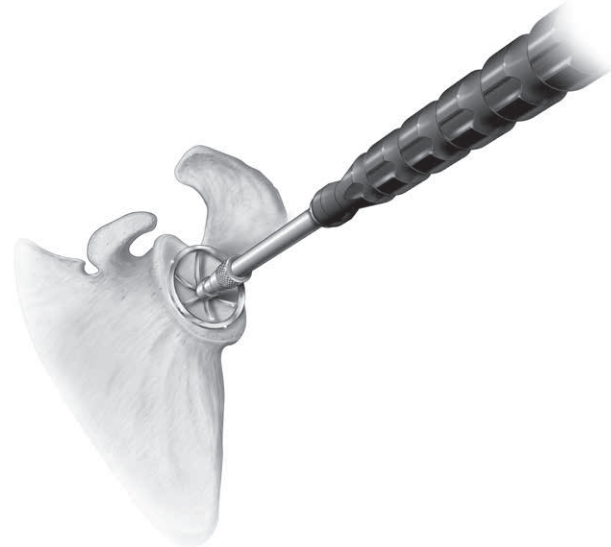

Figure 14
Ream the Glenoid

An **Extra Small Glenoid Reamer** is provided for each reamer type to aid the surgeon in the initial preparation. Connect the appropriately sized **Modular Pilot-Tip Reamer** (note that the reamers are color coded) to the Modular Driver (Figure 13 and Table 3). Sequentially ream the glenoid to the appropriate size (Figure 14). If substantial posterior glenoid erosion is evident, eccentrically ream the glenoid to restore version and ensure the implant is fully supported.

Note: Start the reamer prior to engaging bone.

Note: The central hole may need to be redrilled if substantial reaming has occurred, otherwise the depth of the center hole may not be sufficient.

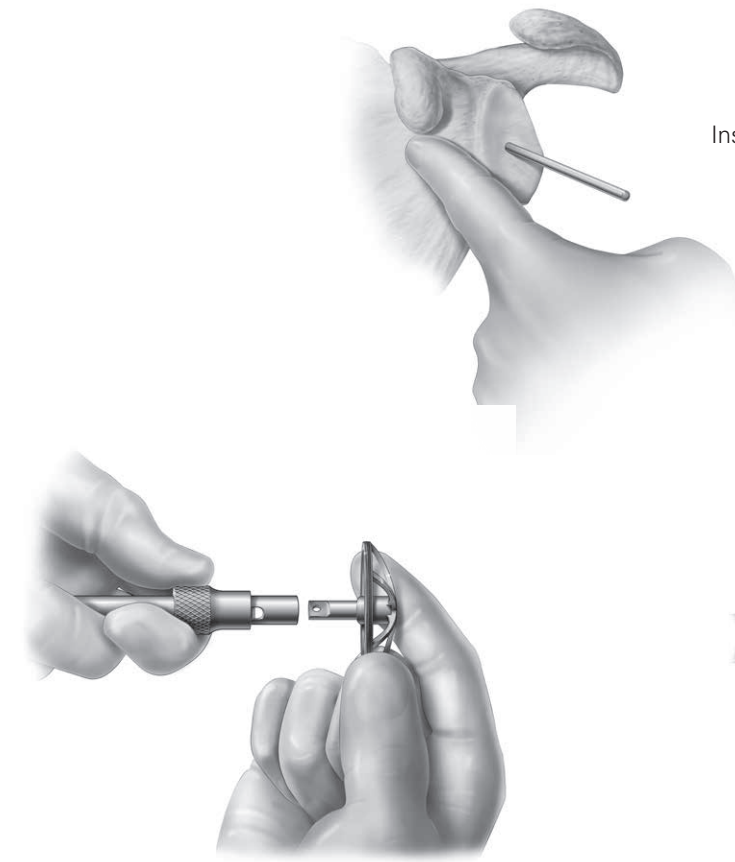

Figure 15
Insert 0.079 in. K-wire

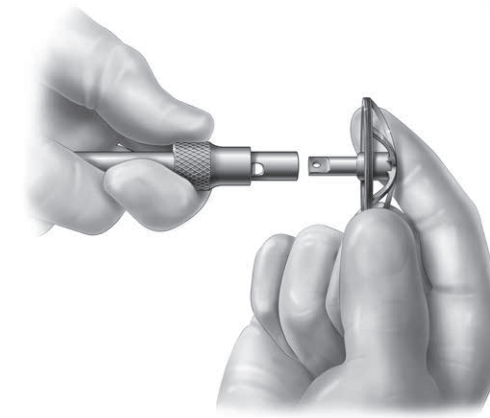

Figure 16
Connect Modular Primary Cannulated Reamer to Glenoid Driver

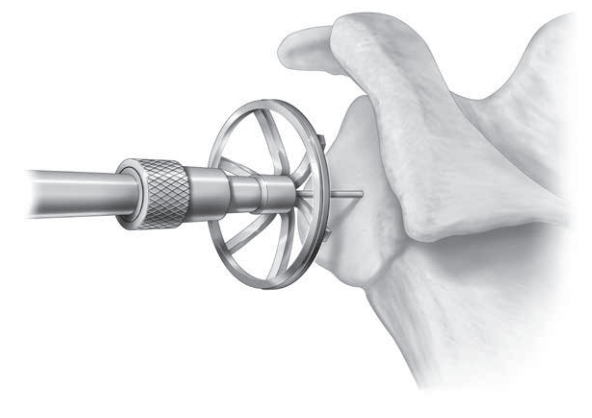

Figure 17
Ream the Glenoid

If using the Cannulated Reamers, drill the 0.079 inch K-wire in the center of the glenoid (Figure 15). **Connect the appropriately sized Modular Cannulated Reamer** (note that the reamers are color coded) to the **Modular Driver** (Figure 16). Sequentially ream the glenoid over the central K-wire to the appropriate size (Figure 17).



Figure 18
Drill the Center Hole

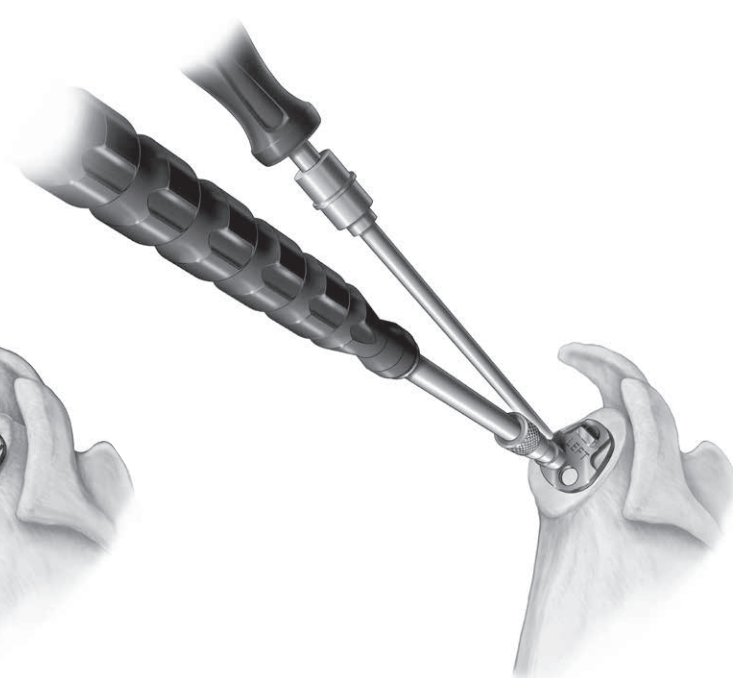

Figure 19
Drill the Pegged Glenoid

After reaming, connect the Modular Cannulated Center Peg/Keel Drill to the Modular Driver and drill the center hole through the Center Hole Drill Guide (*Figure 18*).

Preparing the Cemented Pegged and Cage Glenoid
Connect the **Modular Peripheral Peg Drill** to the Modular Driver and drill the three peripheral holes through the **Peripheral Peg Drill Guide** (*Figure 19*).

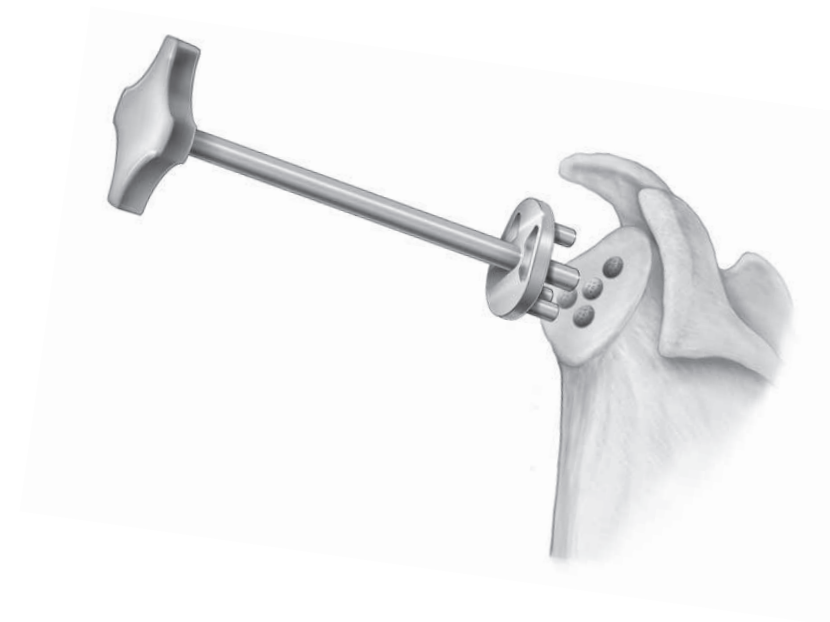

Figure 20
Depth Gauge for
Cage Glenoid to
Confirm Hole Depth

Insert the **Peripheral Peg Holding Pins** into the Peripheral Hole Drill Guide, as needed. For the cage glenoid and prior to insertion of the trial, use the provided **Depth Gauge** to ensure that the holes were prepared to the defined depth (*Figure 20*). If depth gauge is not fully seated, re-drill holes as needed.

Note: The Holding Pins were designed to fit conveniently in Allis clamps for easy insertion.

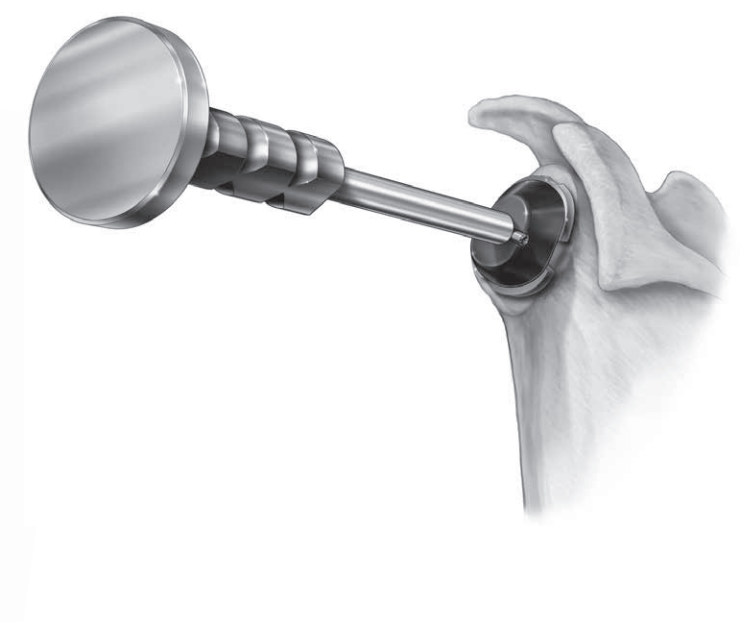

Figure 21
Insert the Trial Glenoid

Finally, ensure proper seating and sizing by inserting the **Trial Glenoid** (*Figure 21*). Since the peg pattern/spacing is the same on all sizes, the surgeon may easily upsize or downsize the Pegged Glenoid to achieve the best coverage (provided that all the cortical bone was reamed).

Note: The center and superior holes should be drilled first; once the inferior holes are drilled, it becomes more difficult to switch to a Keeled Glenoid.

DETAILED OPERATIVE TECHNIQUE

PREPARING THE GLENOID

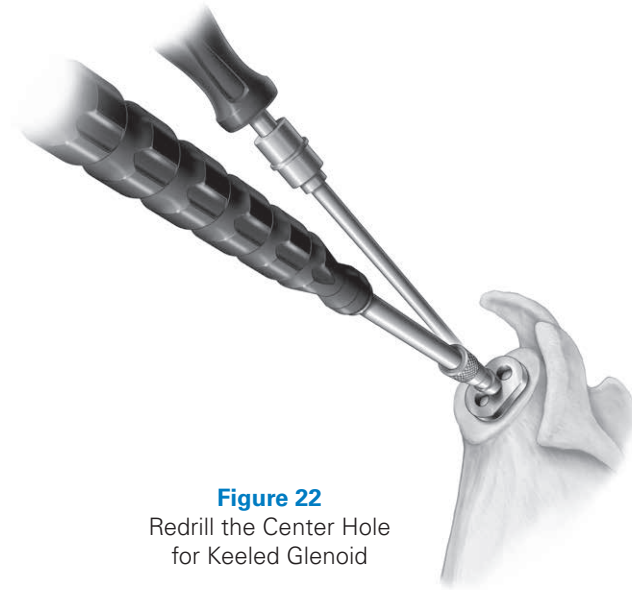

Figure 22
Redrill the Center Hole
for Keeled Glenoid



Figure 23
Drill the Keeled Glenoid

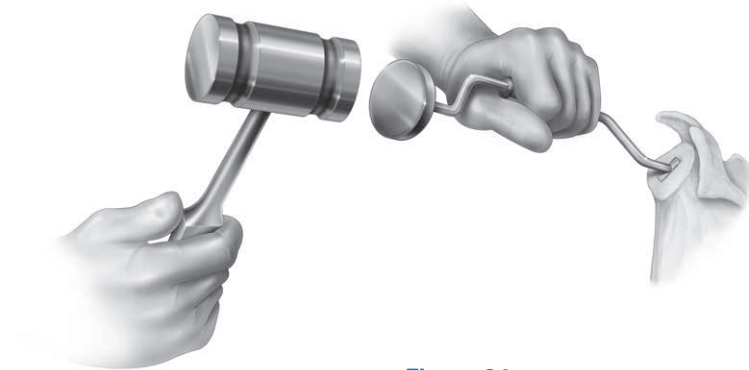

Figure 24
Broach the Keeled Glenoid

Preparing the Cemented Keeled Glenoid

After sequential reaming, ensure that the center hole has been drilled to the appropriate depth by redrilling with the Modular Center Peg/Keel Drill and the **Keel Drill Guide** (Figure 22). Connect the **Center Holding Pin** to the center hole of the Keel Drill Guide and connect the **Modular Peripheral Keel Drill** to the Modular Driver. Use the Modular Peripheral Keel Drill with the Keel Drill Guide to drill the superior hole. Insert an L-shaped Holding Pin into the drilled hole and drill the third (inferior) hole (Figure 23). Use a rongeur or a burr to remove the cortical bone between the holes. Sequentially impact the Keel Broach (starting with the small size) to finalize the trough for the keel (Figure 24).

SURGICAL TIP

Use a rongeur or a burr to remove the cortical bone between the holes.

DETAILED OPERATIVE TECHNIQUE

PREPARING THE GLENOID



Figure 25
Insert the Trial Glenoid

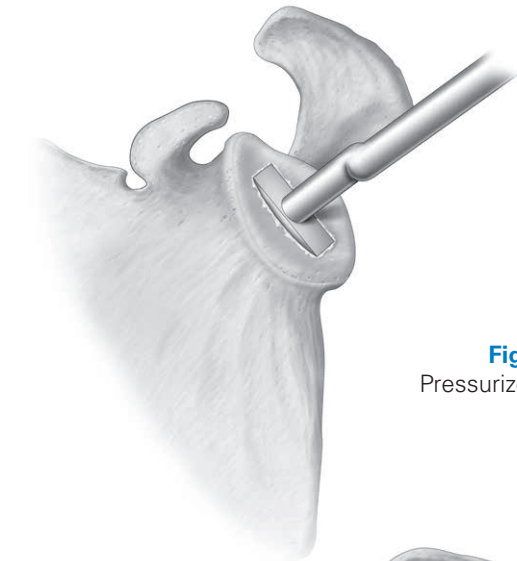

Figure 26
Pressurize the Cement



Do not attempt to countersink the Keel Broach and ensure the Broach only impacts cancellous bone. Finally, ensure proper seating and sizing by inserting the appropriately sized Trial Glenoid (Figure 25).

Note: The medium and large glenoids have the same size keel so there are only two Keel Broaches.

Cementing the Pegged And Keeled Glenoids

Prepare the glenoid by first copiously irrigating the holes to clear any debris. Place thrombin-soaked surgigel, or a similar hemostatic agent, in the prepared keel or peg holes. Cement should be placed on the glenoid and in the drilled the holes. After placing cement, the cement pressurization instruments should be used to pressurize the cement in the glenoid (Figure 26). If performing a pegged glenoid, a **Central Peg** and **Peripheral Peg Pressurizer** are provided. If performing a keeled glenoid, a **small or medium/large Keel Pressurizer** is provided.



Figure 27
Impactor with Glenoid Tip

Figure 28
Seat Glenoid Component
Using Spider Glenoid Impactor

A second injection of cement with thumb pressurization is then completed. Cement is then applied to cover the entire backside of the glenoid component. The glenoid component is then seated using the Glenoid Impactor. Ensure the Glenoid Impactor Tip is fully threaded to the Impactor before striking (*Figure 27*).

Strike the Glenoid Impactor with a mallet to ensure that the glenoid component is in complete contact with the bone. Apply firm, steady pressure on the glenoid with either the Glenoid Impactor or with digital pressure until polymerization is complete. Run a small elevator around the edge of the glenoid component to ensure there is no interposed soft tissue. Excess cement around the edges of the glenoid implant is removed before the cement polymerizes.

Cementing the Cage Glenoid

Prepare the glenoid by first copiously irrigating the holes to clear any debris. Place thrombin-soaked surgigel, or a similar hemostatic agent, in the prepared peg holes. Cement should be placed on the glenoid and in the each of the drilled peg holes. After placing cement, the **Peg Pressurizers** should be used to pressurize the cement in the glenoid (*Figure 26*).

A second injection of cement with thumb pressurization is then completed. Cement is then applied to cover the entire backside of the glenoid component. The glenoid component is then seated using the **Spider Glenoid Impactor** (*Figure 28*). Ensure the approximately sized **Glenoid Impactor Tip** is fully assembled to the impactor handle before striking.

Note: Ensure straight line visibility for cage insertion.

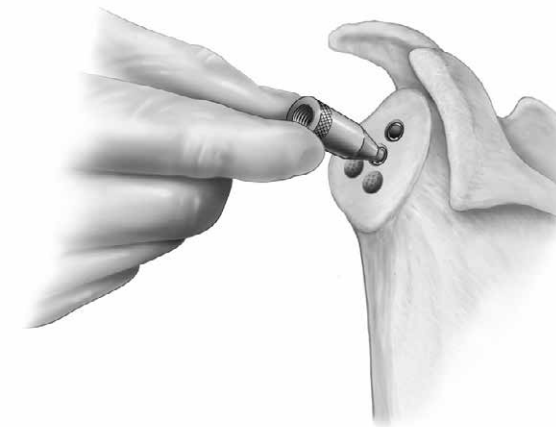

Figure 29
Thread Center Peg
Removal Tool to Internal
Thread of Cage Peg

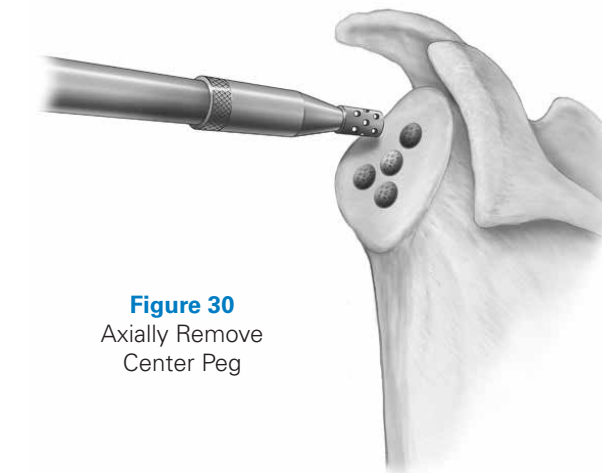

Figure 30
Axially Remove
Center Peg



Figure 31
Thread Peripheral
Peg Removal Tool to
Internal Thread of Each
Peripheral Peg

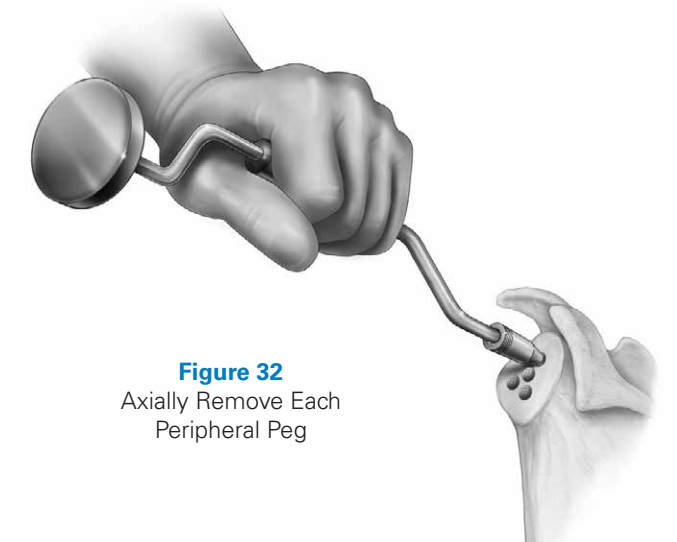

Figure 32
Axially Remove Each
Peripheral Peg

Strike the Glenoid Impactor with a mallet to ensure that the glenoid component is in complete contact with the bone. Apply firm, steady pressure on the glenoid with either the Glenoid Impactor or with digital pressure until polymerization is complete. Run a small elevator around the edge of the glenoid component to ensure there is no interposed soft tissue. Excess cement around the edges of the glenoid implant is removed before the cement polymerizes.

Removing the Cage Glenoid

Should the implant need to be removed after implantation for any reason, a thin flat osteotome should be used between the glenoid backside curvature and the glenoid bone – doing so should disengage the UHMWPE articular surface from the metal pegs. Each metal peg has an internal female thread to facilitate removal of each individually. The **Center Peg Removal Tool** is threaded into the thread of the cage peg (*Figure 29*) and then connected to the Glenoid Impactor Handle and axially disengage (*Figure 30*). Similarly, the peripheral peg removal tool is threaded into each Peripheral Peg (*Figure 31*) and then connected to the Glenoid Impactor Handle to axially disengage (*Figure 32*).

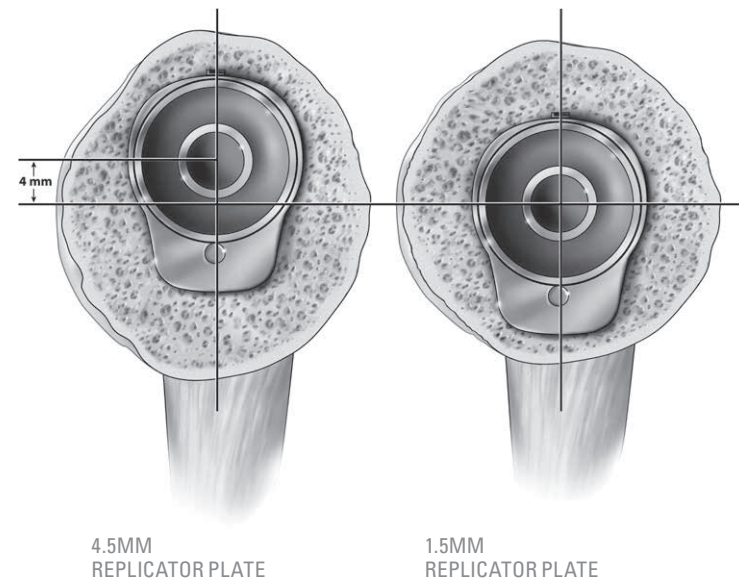

Figure 33
Replicator Plate Options

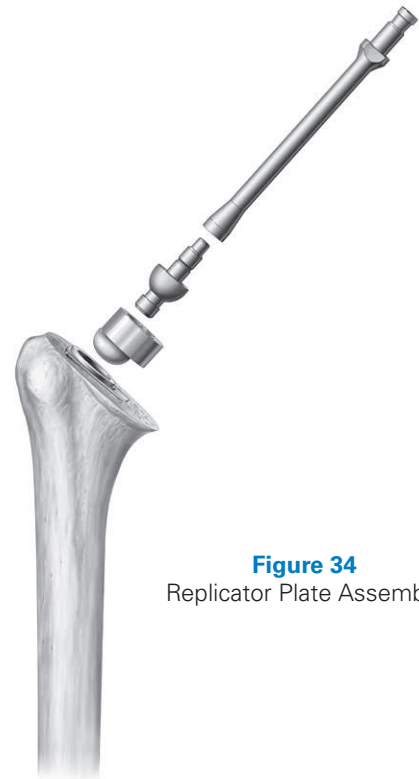
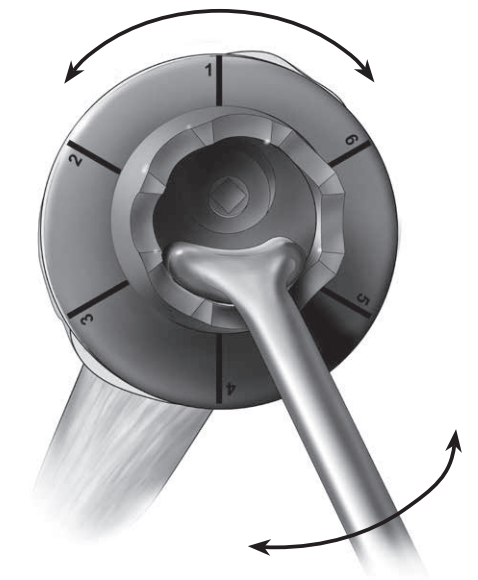

Figure 34
Replicator Plate Assembly



Figure 35
Dual Eccentricities



STEP 5: HEAD POSITIONING

Replicator Plate Selection

Remove the Humeral stem protector and assess the position of the stem's spherical bore in relation to the resected surface of the proximal humerus. In the majority of cases, the stem will be offset from the center of the resected surface (in any direction) by more than 3mm. In this situation, a **4.5mm Replicator Plate** should be used. If this is not the case (i.e. the head is not offset), a **1.5mm Replicator Plate** should be used (Figure 33).

Attaching the Replicator Plate

Attach the Replicator Plate to the stem by hand tightening the Torque Defining Screw with the **Torque Defining Screw Drive** (Figure 34). Once the **Torque Defining Screw** meets resistance, loosen it one turn (this will provide adjustability to the Replicator Plate so the desired head position can be obtained).

Note: The concentric **T-handle** can be used for the initial tightening.

Dialing in the Head Position

Place the appropriately sized **Plate Dial** (diameter matches the options for head implant diameters) on the Replicator Plate and insert the **Replicator Plate Handle** (Figure 35) into the two holes on the Replicator Plate.

The surgeon now has the ability to adjust four independent variables to ensure the prosthesis reproduces the patient's original anatomy: medial offset posterior offset, inclination and version. When the head resection matches the anatomical neck, the surgeon can replicate the patient's anatomy by simply covering the resected humeral surface.

Note: Both the Replicator Handle and the Plate Dial rotate independently to provide dual eccentricities.

The Equinox System provides eccentricity on two components: in the Humeral Head and in the Replicator Plate. These two eccentricities enable the surgeon to reproduce both the medial and posterior offset independently by turning the plate dial and the replicator plate separately. If the surgeon desires to compensate for a less than perfect humeral resection, the system provides +/- 7.5 degrees to adjust the neck angle (inclination) and the version for a total range of 15 degrees for each parameter.

If the surgeon is pleased with the humeral head resection, begin the trialing process with the trial ring parallel to the resection (i.e., neck angle and retroversion match the cut). Cover the resected surface by rotating the trial ring with your fingers and the Replicator Plate with the Replicator Plate



Figure 36
Humeral Head Trial

Handle. Angulation (neck angle and retroversion) adjustments should be assessed during the trial reduction (i.e., if posteriorly unstable, consider reducing the retroversion by loosening the screw and tilting the Replicator Plate.)

Once the Plate Dial is perfectly positioned, tighten the Torque Defining Screw. (This is an interim tightening. The screw is not completely torqued until after assessing the range of motion). Using the numbers on the Plate Dial, take note of the head position or make an identifying mark in order to place the **Head Trial** on the Replicator Plate with the exact same orientation (*Figure 36*). Replace the Plate Dial with the same size Head Trial (color-coded) and assess the range of motion as described below.

Assessing Range of Motion

Assessment of stability is performed in a step-wise sequence. First, the articulation is assessed with the arm at the side. The arm is rotated internally and externally; rotation should be smooth, and the humeral head should maintain a reduced position on the glenoid component. Second, with the arm at the side, anterior, posterior and inferior translation should be assessed. Up to 50 percent posterior and inferior translation is acceptable; up to 25 percent anterior translation is acceptable. Third, range of motion is assessed. The arm should internally rotate to the chest wall without limitation. At 90 degrees of abduction, the shoulder should internally rotate 70 degrees.

		Head Diameter (mm)					
Height		38	41	44	47	50	53
	Short	16	16	17	18	19	20
	Tall	19	20	21	22	23	24
	Expanded				26	27	28

Table 4
Humeral Head Scope

Varying the thickness of the modular Humeral Head provides the ability to optimize stability and range of motion (*Table 4*). If soft-tissue laxity is excessive, a taller Humeral Head may be necessary. Conversely, if soft-tissue tension is excessive, a shorter Humeral Head may be necessary. **In general, the thinnest Humeral Head that provides adequate stability should be used to avoid overstuffing the joint.** If the surgeon desires to further adjust the positioning of the head, simply loosen the screw one-half rotation and repeat the previous steps.

Torque Defining Screw

Once the surgeon is satisfied with the position of the Replicator Plate and the size of the trial Humeral Head, remove the Head Trial and insert the Replicator Plate Handle into the holes located on the surface of the plate. Impact the

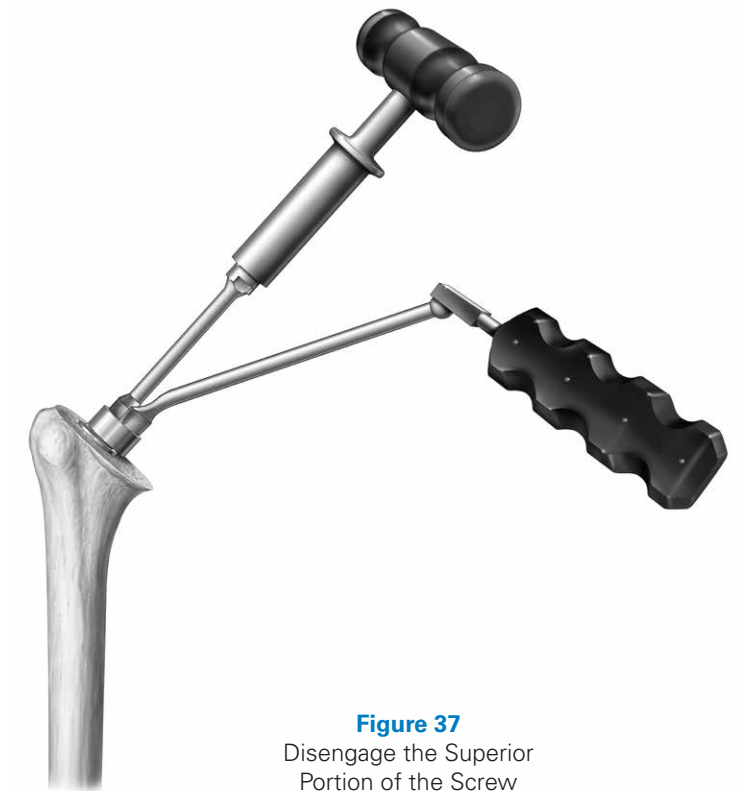

Figure 37
Disengage the Superior Portion of the Screw

T-handle with a Mallet to ensure the driver is fully engaged in the screw. The plate is now ready to be locked into position.

SURGICAL TIP

Impact the T-handle with a Mallet to ensure the driver is fully engaged in the screw. Failure to fully engage the UHMWPE plug on the screw head may prevent the screw head from being retained by the torque defining screw driver.

With one hand, use the T-handle to tighten the screw until the superior portion disengages (*Figure 37*), which will occur at an applied torque of 11 N·m. To prevent the stem from rotating within the canal, a countertorque must be simultaneously applied using the Replicator Plate Handle.



Figure 38
Impact the Humeral Head



Figure 39
Head Removal Tool



Figure 40
Screw Removal Device

After the head of the Torque Defining Screw disengages at 11 N·m, verify that the screw head is retained by the Torque Defining Screw Driver.

The portion of the screw that remains in the implant will have a square head that the surgeon can use to loosen the screw using the **Torque Defining Screw Removal Instrument** should the Replicator Plate ever need to be removed (e.g. revision of hemi to a TSA or reverse).

Impacting the Humeral Head

Clean and dry the visible portion of the Replicator Plate and place the final Humeral Head implant on the Replicator Plate **using the numbers on the bottom of the implant** to replicate the Head Trial orientation. Using the Head Impactor

and a Mallet, strike the head directly in line with the taper to ensure proper engagement of the morse taper (*Figure 38*). Ensure the **Head Impactor Tip** is fully threaded to the Impactor before striking. Hand-test to ensure proper seating.

Revising a Hemi to a TSA

Gaining exposure to the glenoid after a hemiarthroplasty, while rarely easy, is facilitated with the Equinoxe System's removable Replicator Plate. Using the **Head Removal Tool**, lever the head off the Replicator Plate (*Figure 39*).

When the Torque Defining Screw was initially torqued, the portion that snapped off left a square that can be used to remove the screw. Attach the Torque Defining Screw Removal Instrument to the asymmetric T-handle and loosen the screw (*Figure 40*).

The Replicator Plate can now be removed and discarded. Protect the resected humeral surface and humeral stem with the Humeral Stem Protector while the glenoid is prepared. A new Replicator Plate, screw and head should be used to ensure proper engagement of the morse taper.

STEP 6: CLOSURE

Closure is performed beginning with the subscapularis. The repair of the subscapularis will depend on the type of exposure used: tenotomy, elevation off bone or elevation with a wafer of bone. In general, #2 non-absorbable braided suture, or its equivalent, is used for either a tendon-to-tendon, tendon-to-bone or bone-to-bone repair. The rotator interval is then closed, though it may be left partially open medially to avoid excessive tension of the closure. External rotation is checked at this point to define the parameters for post-operative rehabilitation. A drain may be used, placing it deep into the deltopectoral interval. The deltopectoral interval is closed followed by closure of the subcutaneous tissue and the skin. The upper extremity is then placed in a sling and swathe.



Post-Operative Rehabilitation

It is recommended to initiate the rehabilitation program on the same day as surgery and certainly by post-operative day one. All patients begin active range of motion of the elbow, wrist and hand. Range of motion of the shoulder consists of passive forward elevation, external rotation based on the assessment following subscapularis repair and internal rotation to the chest wall (if there is concern about the security of the subscapularis repair, external rotation should be limited to 0 degrees). Isometric deltoid strengthening can also be performed.

Patients should be instructed to perform these exercises five to six times per day for short periods of up to 10 minutes each session. The sling is discontinued after four weeks. A longer period of sling use should be used if there is concern about the soft tissue repair. When the sling is discontinued, active range of motion should begin. Internal rotation behind the back can also be started at this time. Isometric internal and external rotation is added at six weeks and gentle resistive strengthening of the deltoid and rotator cuff begins 10-12 weeks post-operatively. When the sling is removed, the patient is instructed to increase use of the upper extremity for activities of daily living. More vigorous strengthening can be initiated 12 weeks after surgery.



Figure A
Resect Humeral Head



Figure B
Ream Humeral Shaft



Figure C
Broach Humeral Shaft

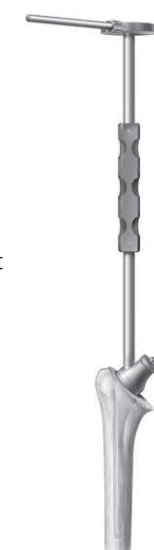

Figure D
Insert Humeral Stem Trial



Figure E
Insert Stem Protector

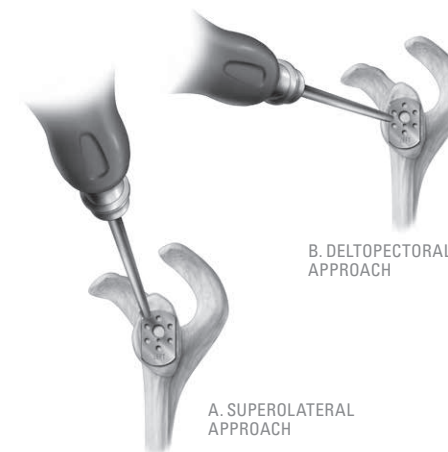

Figure F
Align Drill Guide with Inferior Aspect of the Glenoid



Figure G
Pilot-Tip Option: Drill Reamer Pilot Hole, Ream the Glenoid and Drill Glenoid Plate Hole

OPERATIVE TECHNIQUE OVERVIEW

REVERSE SHOULDER

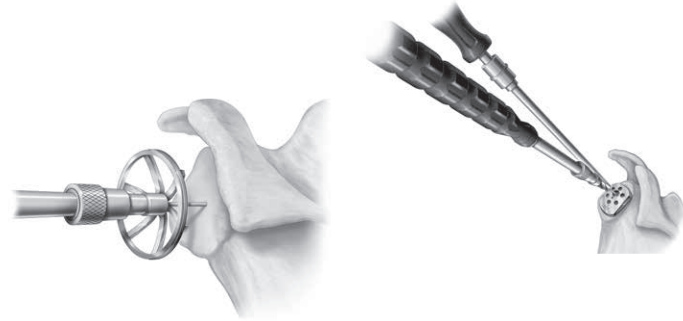

Figure H

Cannulated Option: Insert K-wire, Ream the Glenoid and Drill Glenoid Plate Hole over K-wire



Figure I

Insert Glenoid Plate

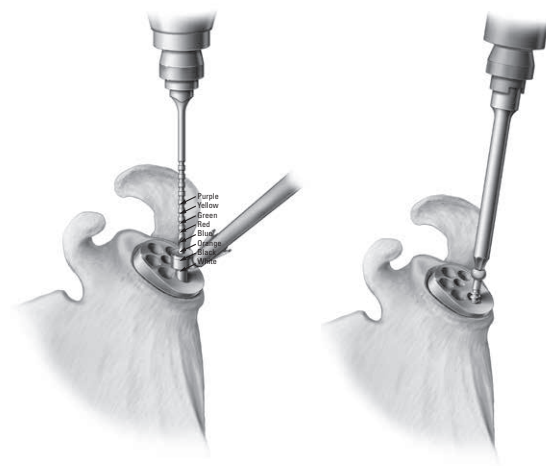

Figure J

Drill and Implant Compression Screws

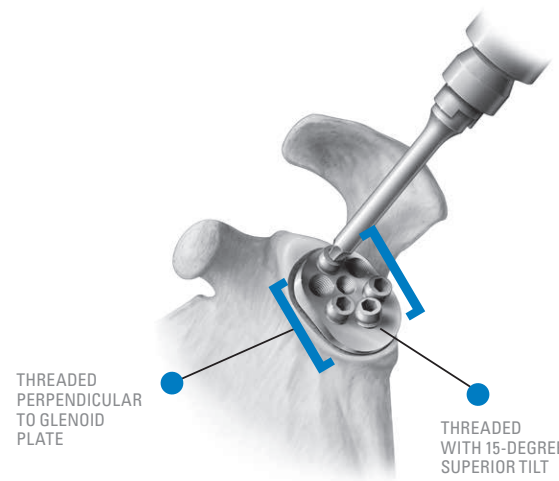

Figure K

Tighten Locking Caps

OPERATIVE TECHNIQUE OVERVIEW

REVERSE SHOULDER



Figure M

Insert Humeral Tray Trial and Liner Trial



Figure N

Remove Liner Trial



Figure O

Insert Definitive Glenosphere



Figure P

Cement Definitive Stem

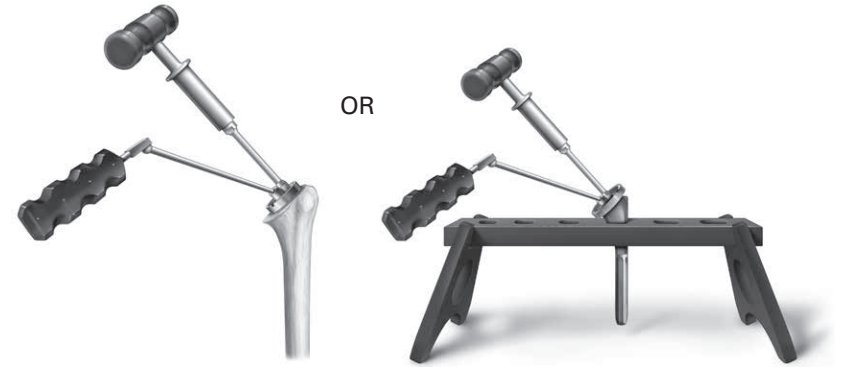

Figure Q

Implant Definitive Tray

GLENSPHERE INSERTER SLIDE AND SPRING HANDLE

UNIVERSAL GLENSPHERE INSERTER CLAMP

TAPERED GLENSPHERE INSERTER

PILOT TAPERED GLENSPHERE INSERTER

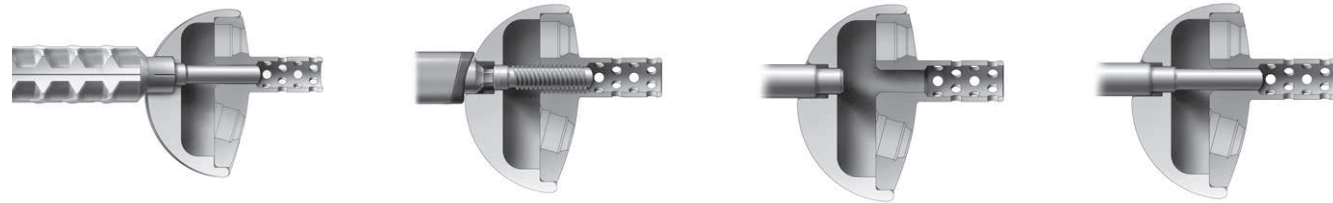

Figure L

Insert Glenosphere Trial



OR



Figure R

Implant Definitive Liner

After a careful history and physical examination, radiographs should be obtained to assess glenohumeral joint space narrowing, osseous deformities and glenoid wear. A CT scan is helpful to assist in the evaluation of the quality of bone stock and to further evaluate bone deformities that may be present. An MRI may be obtained if further evaluation of the soft tissues is determined to be helpful. To aid in pre-operative planning, radiographic templates are provided for the humeral components and glenoid components to approximate the required size and alignment of the implants.

STEP 1: PATIENT POSITIONING

The patient should be placed on an operating table in a supine position. The head of the operating table should be elevated approximately 30 degrees in a modified beach chair position. A small bolster should be placed laterally behind the involved shoulder. The patient should be moved to the side of the table so that the upper extremity can be placed in maximum extension without obstruction by the operating table. Alternatively, a Captain's chair or similar positioning device can be used for proper patient positioning. The patient should be secured to the operating table to minimize any changes in position intra-operatively. The entire upper extremity should be prepped and draped to allow complete access to the operative area and full mobility during the procedure. Either a deltopectoral or a superolateral approach may be used depending on the surgeon's preference and clinical parameters.

STEP 2: SURGICAL APPROACH

Deltopectoral Approach

An anterior deltopectoral incision is made beginning inferior to the lateral clavicle, passing over the coracoid process and extending distally toward the deltoid insertion. Medial and lateral subcutaneous flaps are created, and the deltopectoral interval is identified.

A thin fat stripe is often located over the cephalic vein. The interval is usually developed medial to the cephalic vein; the interval can also be developed laterally depending on the surgeon's preference. Branches of the cephalic vein on the approach side are cauterized, and the interval is developed inferior to superior to expose the clavipectoral fascia.

The advantage of retracting the cephalic vein with the deltoid is that the majority of the branches enter from the deltoid. The disadvantage is the vein is more exposed to injury from the retractor as it crosses the superior aspect of the interval. The subdeltoid space is mobilized with a blunt elevator. The clavipectoral fascia is incised longitudinally up to the coracoacromial ligament (which is spared), and the conjoined tendon is mobilized. A self-retaining retractor is placed with care to avoid excessive traction on the conjoined tendon. The coracoacromial ligament is identified and the subacromial

space is mobilized with a blunt elevator. The subscapularis tendon insertion (if present) on the lesser tuberosity is identified along with the rotator interval. The anterior humeral circumflex vessels along the inferior border of the subscapularis muscle (the "three sisters") are cauterized extensively. The axillary nerve should be palpated in its position at the inferomedial border of the subscapularis. Exposure of the nerve for direct visualization can be performed at this point based upon surgeon preference. The biceps tendon (if present) is palpated in its groove. A biceps tenodesis can be performed at this point by dividing the tendon in the mid-portion of the groove and securing it either to the adjacent soft tissues or to bone based upon surgeon preference. The subscapularis tendon and the capsule are tenotomized 1cm medial to the lesser tuberosity and tagged with #1 sutures. The inferior capsule should be released from the humeral neck to allow the humerus to be externally rotated 90 degrees. As this release is performed, the axillary nerve should be protected by placing a blunt elevator between it and the inferior capsule.

An alternative approach is to elevate the subscapularis directly off the bone or elevate its insertion with a thin wafer of bone (1-2mm thick) using an osteotome. The choice of subscapularis detachment and subsequent reattachment is based primarily on surgeon preference. In some cases, particularly with revision surgery, the subscapularis may be absent or only the inferior portion may remain.

Exposure of the subacromial space will reveal a massive rotator cuff defect. Often there is an extensive amount of fibrous and bursal tissue filling this area that should be excised. The humerus can then be placed in extension, adduction and external rotation to begin preparation of the humerus. The large deltoid retractor should be used to enhance exposure of the proximal humerus.

Superolateral Approach

A superolateral incision is made beginning at the anterior edge of the acromion and directed posterolaterally in an oblique direction. Subcutaneous dissection is performed to raise generous flaps medially and laterally. The interval between the anterior and middle portions of the deltoid is identified and this interval is developed superiorly over the top of the acromion. In doing so, the anterior deltoid is detached from its acromial attachment along with the coracoacromial ligament insertion. The interval is developed up to 4cm distally from the acromion to avoid potential injury to the axillary nerve. This provides exposure of the subacromial space, which is usually filled with fibrous and bursal tissue that should be removed to expose the humeral head. Any remaining intact rotator cuff should be visualized and usually includes a portion of the subscapularis and teres minor, although one or both may be absent.



Figure 41
Humerus

The humerus should be placed in extension, adduction and external rotation along with superior displacement to dislocate the humeral head anterosuperiorly for exposure. Once again, the large Deltoid Retractor can be used to enhance visualization and exposure of the proximal humerus.

STEP 3: HUMERAL PREPARATION

Humeral Head Resection

Prior to humeral head resection, all osteophytes should be removed using a Rongeur (*Figure 41*). Doing so will properly allow identification and exposure of the anatomic humeral neck. An aggressive resection at, or just distal to, the anatomic neck is recommended. Care should be taken not to make a resection with more than 20 degrees of retroversion as this will limit internal rotation.

Anatomic Cutting Guide: The Equinoxe

Anatomic Cutting Guide enables the surgeon to accurately resect the humeral head along, or just distal to, the anatomic neck without the use of intra- or extra-medullary alignment guides or cutting guides. The jaws of the cutting guide should be placed at, or just distal to, the anatomic neck and used as a cutting surface for the resection.

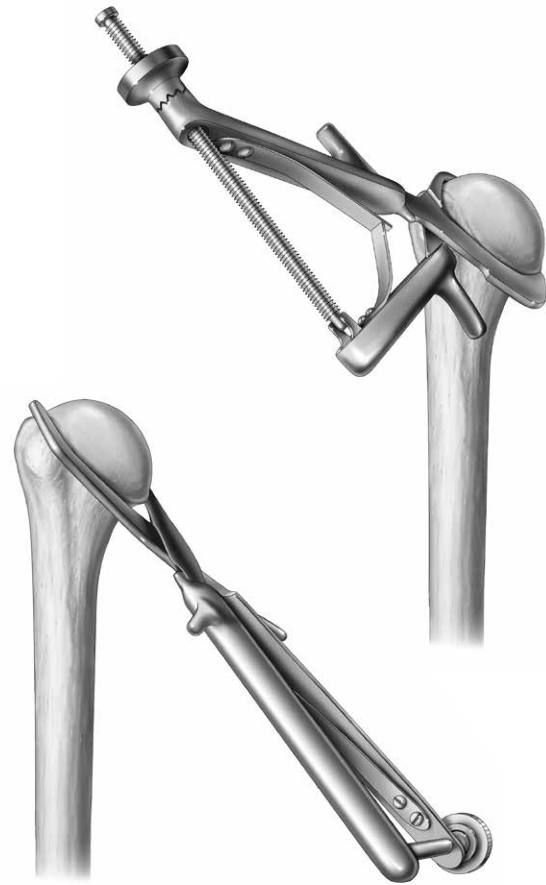

Figure 42
Anatomic Cutting Guide



Figure 43
Fixed Angle Cutting Guide



Figure 44
Insert Reamer

The resection should proceed from inferior to superior. The smaller jaw of the guide should be placed along the sulcus adjacent to the greater tuberosity superiorly. The wide jaw should be in direct contact with the medial and inferior portion of the anatomic neck. Alternatively, an anterior-posterior cutting approach can be used with the thin jaw encircling the posterior side of the anatomic neck and the cutting jaw positioned anteriorly (Figure 42). Once the guide is in position, it is secured using the threaded knob. To ensure the cutting guide does not change position, the handle should be gripped while the osteotomy is performed; alternatively, two small K-wires (0.062 inches) can be inserted through the cannulated portions of the wider jaw.

Note: Removing the osteophytes is suggested in order to visualize the anatomic neck, but it also improves the bite obtained by the teeth on the cutting guide.

Free Hand: The anatomic neck is identified and the head is resected using a microsagittal saw at, or just distal to, the anatomic neck.

Fixed Angle (132.5 degrees) Cutting Guide: Three options are available for the Fixed Angle Cutting Guide (Figure 43):

- 1) Using the cutting surface to mark the resection line with a bovie and then use the free hand method
- 2) Attaching the guide to a handle, which aligns with the forearm to provide 20 degrees of retroversion

3) Using K-wires to secure it to the proximal humerus. The Fixed Angle Cutting Guide is not used from the superior approach. Once the head is resected, the surgeon can either proceed directly to the glenoid or continue to prepare the humerus. The latter allows the stem protector to be used to minimize damage to the proximal humerus while exposing the glenoid.

Reaming the Humeral Shaft

The smallest Reamer (7mm) has a sharp tip to facilitate the initial entry into the IM canal (Figure 44). The entry point is made just posterior to the bicipital groove and at the junction of the middle and upper thirds of the resected humeral surface. The canal should be sequentially reamed until endosteal cortical contact is obtained. It is imperative

that the Reamer be inserted into the canal to the appropriate depth as indicated by the depth markers; reaming prepares the canal for the distal diameter of the stem and determines the final diameter of the definitive stem. There is no need for forceful reaming. If there is difficulty fully inserting a reamer, the broach and implant selected should be the size of the last reamer that was completely seated. If there is any concern about the size of the implant to use, the smaller alternative should be selected since the stem will be cemented in place.

Note: To ensure the adequate depth is achieved, ream until the depth marker is no longer visible.

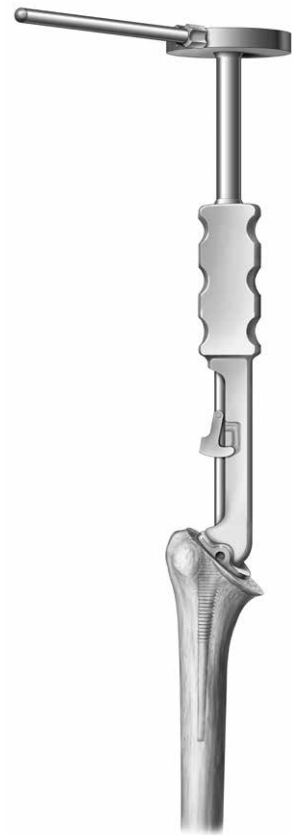

Figure 45
Insert Broach



Figure 46
Insert Stem Trial



Figure 47
Implanted Stem Trial



Figure 48
Stem Protector

Broaching the Humeral Shaft

After the canal has been reamed, the smallest Broach (7mm) is attached to the Broach Handle (*Figure 45*). The Broach should be inserted into the canal at a version consistent with that of the cut surface (i.e., the broach collar should be flush with the resected surface). The canal should be sequentially broached until the size of the Broach matches that of the final Reamer. Each Broach should be impacted until contact is made between the metaphyseal surface and the broach collar. The Broach should not be countersunk and only the strike surface should be used for impaction.

As a visual check to assess version, the Retroversion Handle can be attached to the Broach Handle ("L" and "R" indicate appropriate side) and aligned with the patient's forearm

(assuming the patient has a stable elbow). The Retroversion Handle, when aligned with the forearm, indicates 20 degrees of retroversion. Care should be taken not to broach in more than 20 degrees of retroversion as this will limit internal rotation.

Note: The Broach is securely locked to the Broach Handle when the latch is returned to the starting position.

Inserting the Humeral Stem Trial

The trial humeral stem size is determined by the largest Reamer that was fully inserted to the appropriate depth (*Figure 46*). The Humeral Stem Trial is attached to the Stem Inserter and impacted until it is fully seated in the humerus (*Figure 47*). **The trial is sized line-to-line with the Broach and Reamer. It is important to note that the reverse humeral component is intended to be used in either cemented applications or with an uncemented Equinox stem in revision cases when the component is well-fixed and stable, as determined by the orthopaedic surgeon's clinical and radiographic assessment.**

Humeral Stem Protector

The humeral Stem Protector should be placed into the proximal portion of the implanted stem to protect the resected surface during glenoid preparation (*Figure 48*).

Note: The Stem Protector is offset so it can be rotated to ensure the best possible coverage.

STEP 4: PREPARING THE GLENOID

Glenoid Exposure

Retractors are provided to aid in glenoid exposure. A Posterior Glenoid Retractor (e.g. **Wolfe Retractor**) should be used to displace the proximal humerus posteriorly. A single- or double-spiked glenoid retractor is then placed anteriorly along the glenoid neck. Hohmann Retractors are placed superiorly and inferiorly around the glenoid.

The glenoid labrum is excised circumferentially to expose the entire surface of the glenoid. Any remaining portions of the biceps tendon also should be excised. There is often a significant amount of tissue around the glenoid that represents bursal tissue and remnants of rotator cuff tendons. This should be excised to enhance visualization. The superior, anterior and inferior capsule should be released both for exposure and mobilization. A posterior capsular release may be beneficial to allow the proximal humerus to be retracted posteriorly for adequate glenoid exposure.

At this point, the degree and location of glenoid erosion can be visualized. This should be carefully and completely assessed so that glenoid reaming can be performed to provide proper orientation of the glenoid component. Exposure of the glenoid also will be facilitated by use of specific retractors. For a deltopectoral approach, a Posterior Glenoid Retractor is essential. The **Forked and Wolfe Retractors** provided in the instrument set can be useful for this purpose. Levering retractors should be placed anteriorly, superiorly and inferiorly to expose the glenoid margins.

When a superior approach is used, the inferior capsular release is particularly important. The Forked Retractor can then be placed inferiorly to retract the proximal humerus posteroinferiorly for glenoid exposure. Levering retractors should be placed anteriorly, superiorly and posteriorly as described.

Note: While the Equinox Glenoid Plate does not need to be inferiorly tilted or angled, it should not be implanted with a superior tilt. A neutral orientation is ideal.

Reaming the Glenoid

The Equinox Reverse System provides two options to ream the glenoid: 1) **Pilot-Tip** and 2) **Cannulated Reamers** (Figure 49a,b). Cannulated Reamers rotate about a 0.079 inch K-wire and provide the surgeon maximum precision.

Note: Avoid applying a bending force to the pilot tip reamer or using the reamer to retract the humeral head as this may cause fracture of the 2mm K-wire or pilot tip.

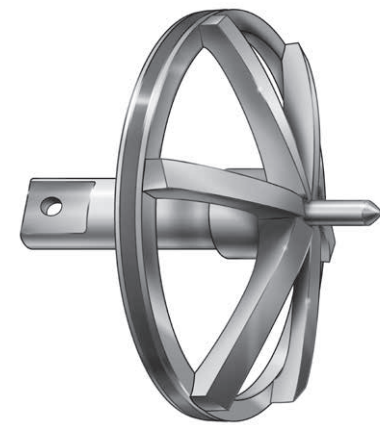

Figure 49a
Pilot-Tip Reamer



Figure 49b
Cannulated Reamer



Figure 50a
Deltpectoral Approach



Figure 50b
Superolateral Approach

Regardless of the reaming option, the **Modular Glenoid Plate Drill Guide** and baseplate should be aligned 1-2mm distal to the inferior glenoid rim to avoid scapular notching (Figure 50a,b). This ensures the glenosphere is properly positioned in a superior-inferior position. Palpate the anterior glenoid neck to determine the angle for glenoid reaming.

Note: Two handle orientations are offered for the two different surgical approaches.

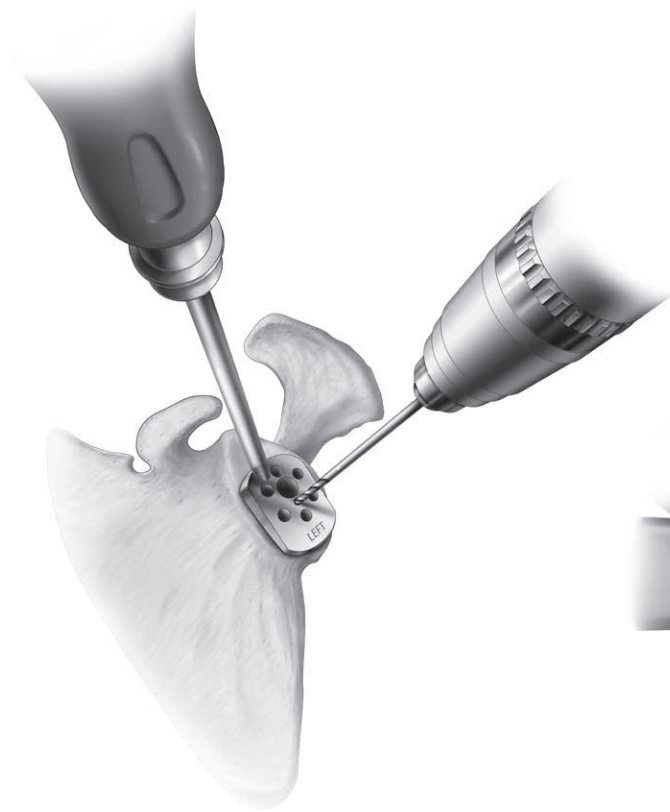

Figure 51
Drill 2mm Pilot Hole

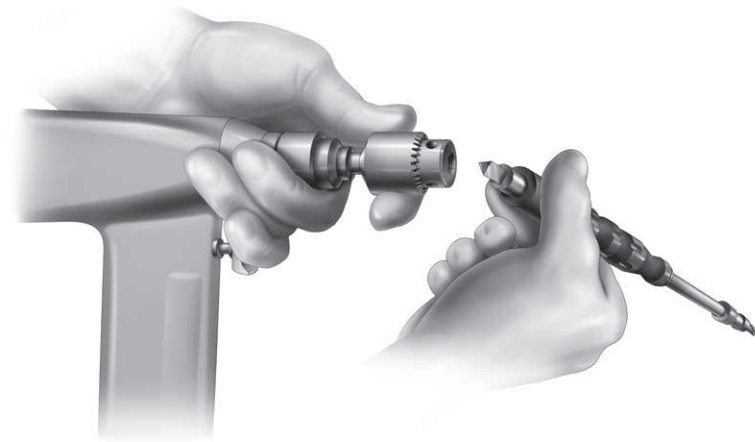

Figure 52
Connect the Modular
Glenoid Driver

Pilot-Tip Reamers

If using the Pilot-Tip Reamers, the 2mm pilot hole is drilled to create the central axis for reaming the glenoid (Figure 51). The **Reverse Starter Reamer** is provided for each reamer type to aid the surgeon in initial preparation. Connect the Modular Glenoid Driver to the powered hand piece using a Jacobs Chuck (Figure 52).

Size	Color of Reamer and Trials
38	Blue
42	Yellow
46	Orange

Table 5
Color-coded Reamers and Trials

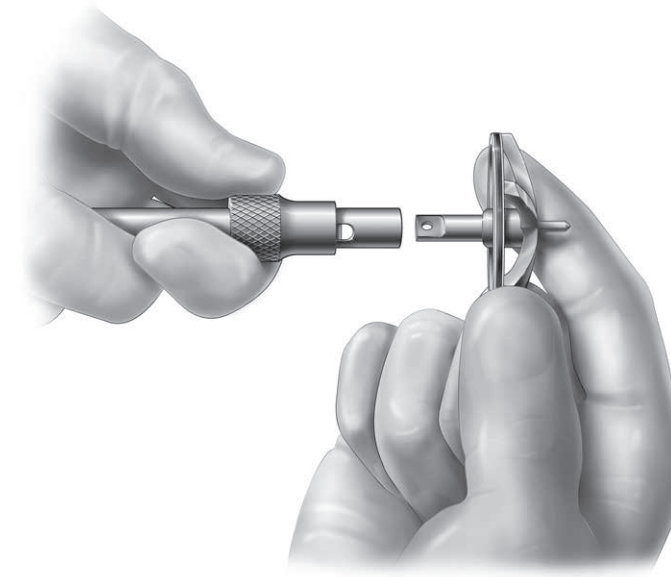

Figure 53
Connect Modular Reverse Pilot-Tip
Reamer to Glenoid Driver

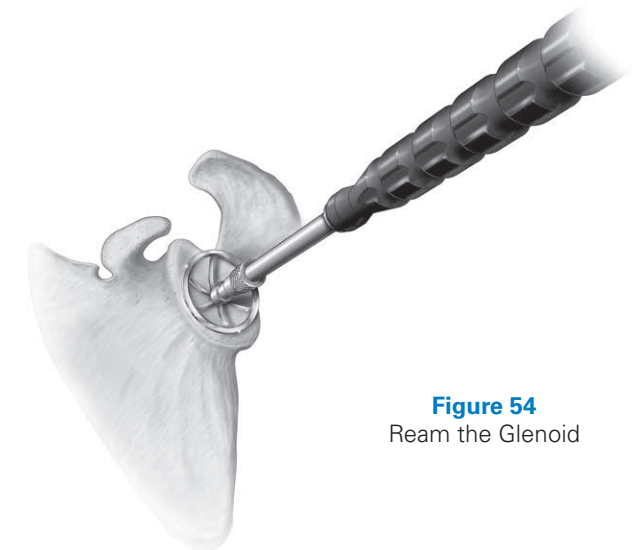

Figure 54
Ream the Glenoid

Next, connect the appropriately sized **Modular Reverse Pilot-Tip Reamer** to the **Modular Driver** (Figure 53).

The reamer tip is placed into the drilled pilot hole and the glenoid is sequentially reamed until any pre-identified glenoid erosions are corrected and the glenoid surface has been fully contoured (Figure 54). Reaming begins with the Reverse Shoulder Starter Reamer and progresses to the 38mm, 42mm and 46mm sizes based upon the anticipated size of the glenosphere.

It is critical to ream to the size of the largest potential glenosphere that the surgeon might use to ensure that the glenosphere will fit on the face of the glenoid without peripheral bony impingement (i.e., the glenoid plate will already be fixed to the glenoid and upsizing the glenosphere during trialing will not be possible if the corresponding reaming has not already been performed). Reamers are available in color-coded sizes that correspond to the three sizes of Glenospheres as described in Table 5.

SURGICAL TIP

Start the reamer prior to engaging bone.

Size	Color of Reamer and Trials
38	Blue
42	Yellow
46	Orange

Table 5
Color-coded Reamers and Trials

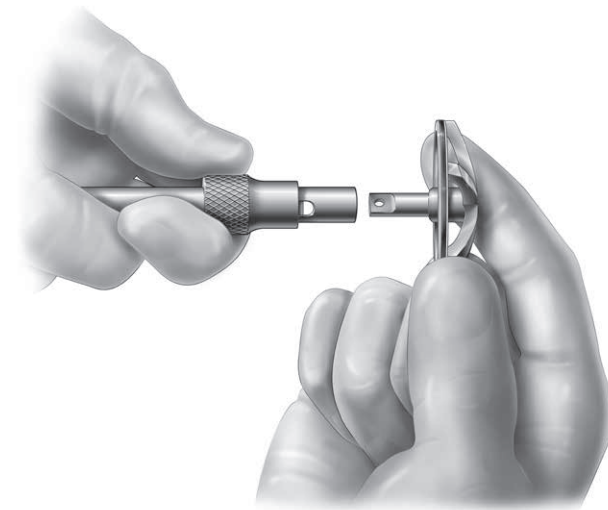

Figure 55
Connect Modular Reverse Cannulated Reamer to Glenoid Driver

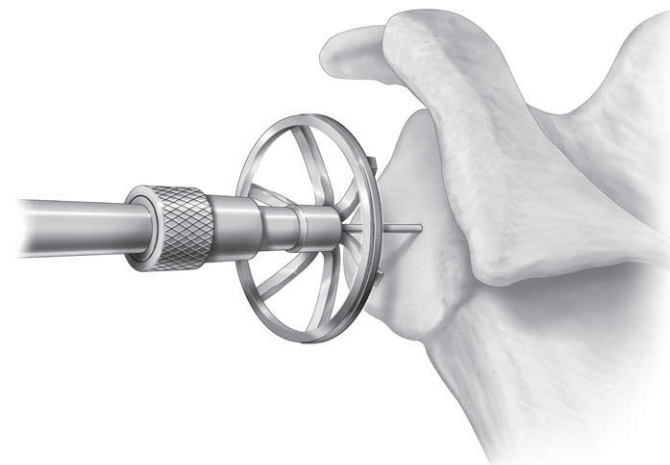

Figure 56
Ream the Glenoid

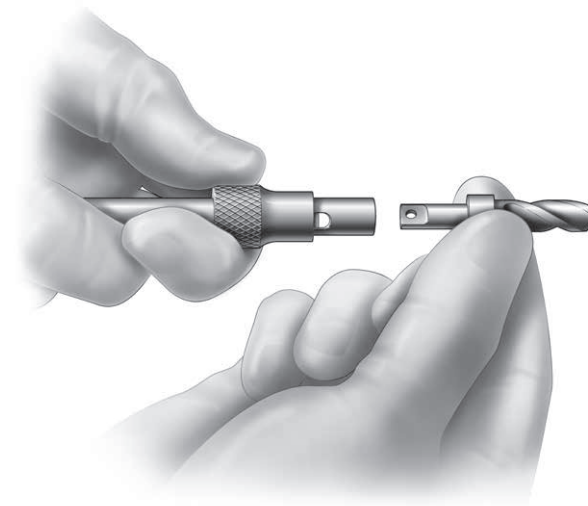

Figure 57
Connect Modular Glenoid Plate Drill to Glenoid Driver

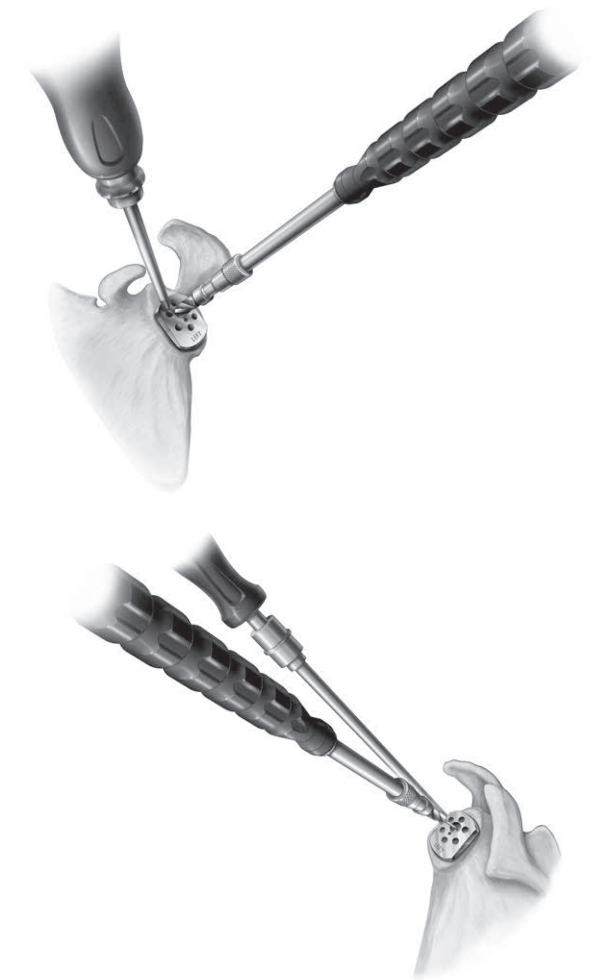

Figure 58
Drill Glenoid Plate Hole

Cannulated Reamers

If using the Cannulated Reamers, align the **inferior aspect** of the **Modular Glenoid Plate Drill Guide** with the **inferior aspect** of the native glenoid bone. Drill the 0.079 inch K-wire through the 2mm pilot hole of the Modular Glenoid Plate Drill Guide. Connect the appropriately sized Modular Cannulated Reamer (note that the reamers are color coded) to the Modular Driver (*Figure 55*).

Reaming begins with the Reverse Shoulder Starter Reamer and progresses to the 38mm, 42mm, and 46mm sizes based upon the anticipated size of the glenosphere. Sequentially ream the glenoid over the K-wire until any pre-identified glenoid erosions are corrected and the glenoid surface has been fully contoured (*Figure 56*).

It is critical to ream to the size of the largest potential glenosphere that the surgeon might use to ensure that the glenosphere will fit on the face of the glenoid without peripheral bony impingement (i.e. the glenoid plate will already be fixed to the glenoid and upsizing the glenosphere during trialing will not be possible if the corresponding reaming has not already been performed). Reamers are available in color-coded sizes that correspond to the three sizes of Glenospheres as described in *Table 5*.

Drill Cage Hole through Drill Guide

After reaming has been completed, the **inferior aspect** of the Modular Glenoid Plate Drill Guide is realigned with the **inferior aspect** of the glenoid. Connect the **Modular Glenoid Plate Drill** to the **Modular Driver** to prepare the glenoid for the cage hole of the Glenoid Plate (*Figures 57 and 58*). The Glenoid Plate Drill is 7.3mm in diameter. The Glenoid Plate cage is tapered and varies in diameter between 7.5mm at its end to 8.1mm where it joins the back of the Glenoid Plate.

Note: *Modular Cannulated Center Peg Drill Option: After reaming over the 0.079 inch K-wire, drill over the existing K-wire with the Modular Cannulated Center Peg Drill.*



Figure 59
Assemble the Glenoid Plate
with Bone Graft



Figure 60
Insert Glenoid Plate



Figure 61
Implant Glenoid
Plate

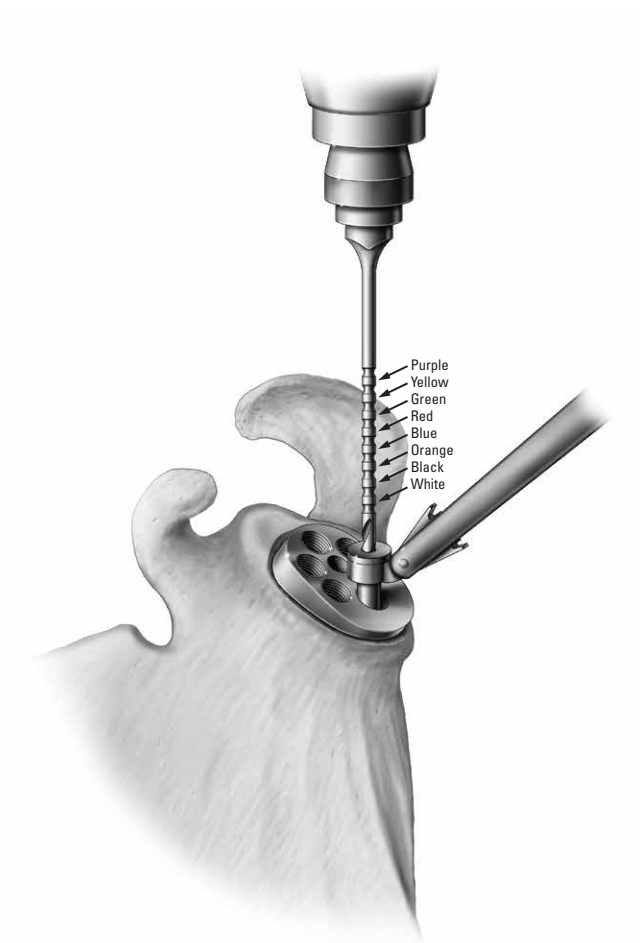

Figure 62
Drill Inferior Hole

Bone Graft for Glenoid Plate

Two options exist for placing bone graft in the glenoid plate's cage (Figure 59).

- 1) Using the **Glenoid Plate Coring Reamer** to create a 6mm autograft bone column from the humeral head, or other suitable location as deemed appropriate by the surgeon, and inserting the bone column directly into the cage.
- 2) Placing allograft (e.g., 1cc of either Optecure® with ccc or Optecure in a syringe) or morselized autograft manually into the cage.

Note: Take care to prevent bone graft from getting on the screw-hole threads as this could prevent adequate screw engagement.

Implanting the Glenoid Plate

Once the cage hole is drilled, the Glenoid Plate is attached to the **Glenoid Plate Inserter** and the Glenoid Plate is press-fit into position taking care to respect the correct rotational orientation (**i.e., the guide and baseplate should be aligned 1-2mm distal to the inferior glenoid rim to avoid scapular notching**) (Figure 60).

The Inserter connects to the **bottom half** of the Glenoid Plate such that the central pin aligns with the threaded central hole and the peripheral legs connect to the bottom peripheral holes of the Glenoid Plate.

Four of the six potential screw locations that will provide optimal fixation and support of the glenoid plate are identified. Primary reverse shoulders will most typically use the superior and three inferior holes based on the anatomy of the native glenoid. The two peripheral holes on the superior part of the plate are intended for revision cases in which the native glenoid bone is compromised. However, each case should be individualized and the six holes provide the surgeon with additional options to maximize fixation of the Glenoid Plate (Figure 61).

Four holes should be drilled using the **Adjustable Angle Drill Guide** and the **3.2mm Drill** (Figure 62), taking note of the depth of each hole using either the color-coded drill or the traditional depth guide. Each hole allows 30 degrees of angular variability so the orientation of the screws can be selected to maximize purchase.

Note: The central cage of the glenoid plate limits the angular variability to 20 degrees for converging anterior, posterior and superior screws.



Figure 63
Implant Screw

Length (mm)	Diameter (mm)	Color-code
18	4.5	White
22	4.5	Black
26	4.5	Orange
30	4.5	Blue
34	4.5	Red
38	4.5	Green
42	4.5	Yellow
46	4.5	Purple

TABLE 6
Compression Screws

The inferior screw should track along the inferior scapular neck and the superior screw should be targeted to track along the base of the coracoids (*Figure 63*). The anterior and posterior screws should be inserted where the surgeon feels the best bone purchase can be achieved, taking note not to drill into the central cage of the Glenoid Plate.

The 4.5mm **Compression Screws** are provided in lengths between 18mm and 46mm, in 4mm increments. The appropriately sized Compression Screws (*Table 6*) are inserted into the drilled holes to achieve fixation and compression of the Glenoid Plate to the glenoid. If power is used to initially insert the screws, caution should be taken to perform the final seating by hand. This will maximize fixation.

A **Ratcheting Screw Drive** is included in the instrument set to facilitate the placement and tightening of the screws.

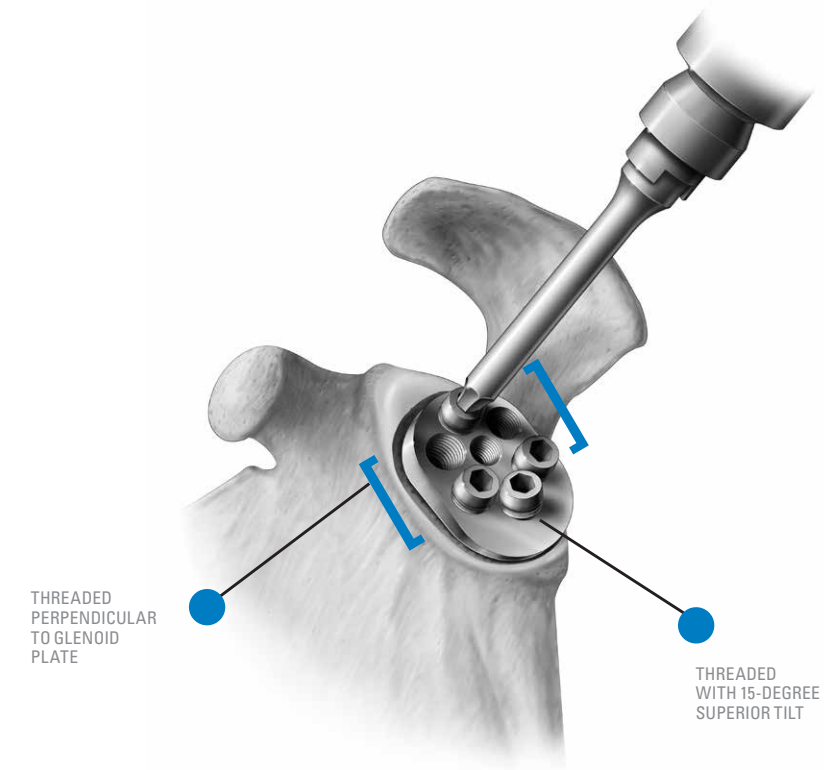

Figure 64
Locking Cap

After all Compression Screws are tightened by hand, as deemed appropriate by the orthopaedic surgeon, the surgeon should insert the Locking Caps into each screw hole. This will lock each Compression Screw and prevent the screws from backing out. Each Locking Cap is inserted perpendicular to the plate with the exception of the inferior one, which must be threaded at a 15-degree superior tilt (*Figure 64*).

Inserting the Glenosphere Trial

Attaining adequate glenoid exposure is critical for this step, especially posterior glenoid exposure. The Posterior Glenoid Retractor included in the set can help provide the posterior clearance necessary to implant the **Glenosphere**.

The appropriately sized Glenosphere is defined by implanting the largest one that can be inserted based upon exposure and the coracoacromial arch anatomy (ensuring that it was reamed up to that size during the glenoid reaming step).

Take note that unlike circular baseplates, the anatomical shape of the Equinox Glenoid Plate mandates that the Glenosphere can only fit in one specific orientation (i.e., the superior/inferior axis of the glenoid).

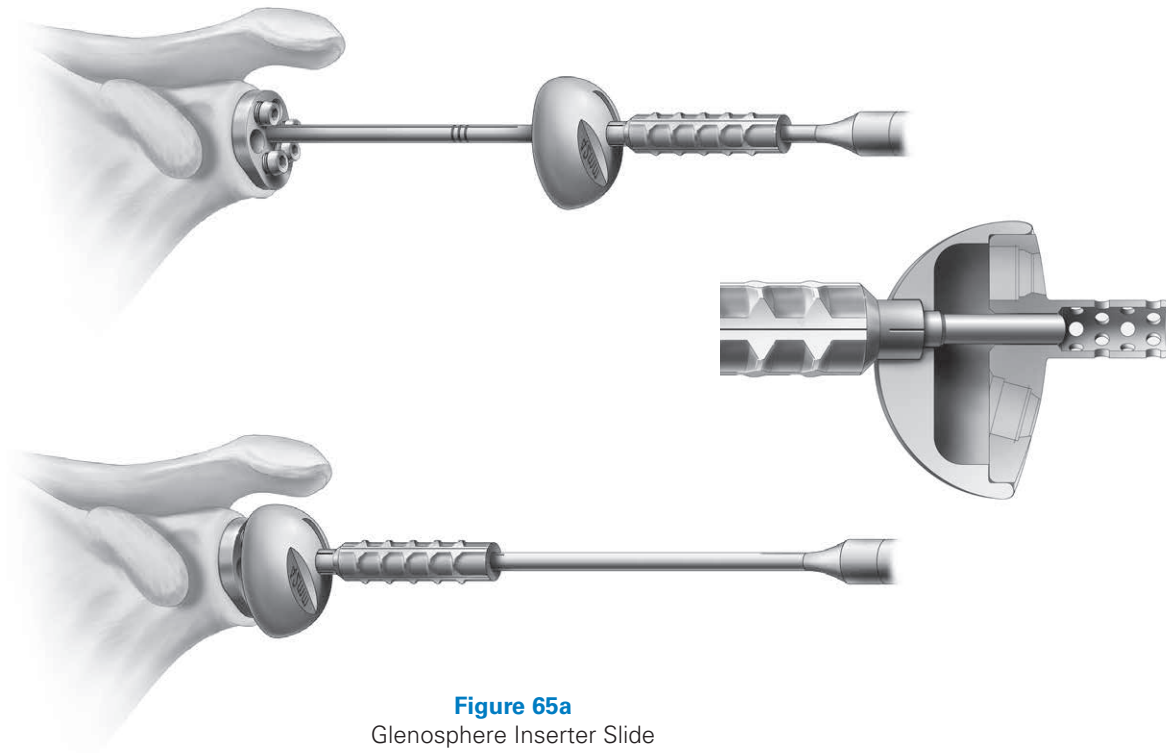

Figure 65a
Glenosphere Inserter Slide
and Spring Handle

Attach the spring handle to the apical hole of the glenosphere so that rotational control is achieved. Place the pilot tip of the inserter slide through the spring handle and glenosphere and into the baseplate. Three circumferential laser marks (corresponding to the three sizes of glenospheres) are included on the slide to indicate the glenosphere has been fully seated on the baseplate. Additional alignment laser marks are included to help the surgeon maintain the correct orientation of the glenosphere. Maintain digital pressure on the glenosphere while removing the inserter (*Figure 65a*).

Universal Glenosphere Inserter Clamp: To engage the glenosphere, use the hook to grab the anterior cavity of the glenosphere so that rotational control is achieved. The Glenosphere Locking Screw may be inserted prior to engaging the handle or it can be inserted through the handle after it is in place. Once the inserter is attached to the glenosphere, insert the hex drive through the handle to engage the tip of the locking screw. This will hold the glenosphere in place during insertion. The glenosphere can then be maneuvered onto the Glenoid Plate by using the

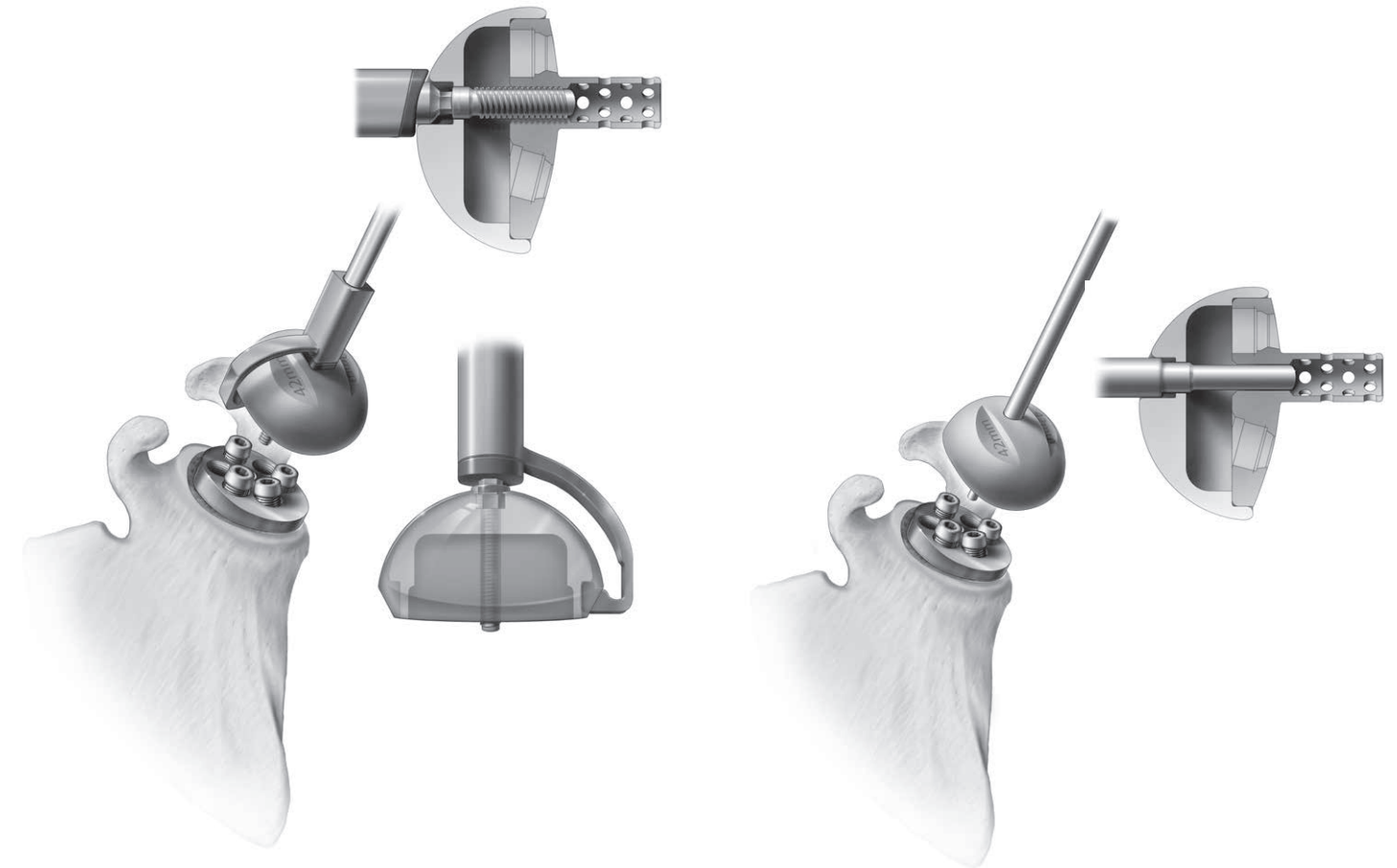

Figure 65b
Universal Glenosphere
Inserter Clamp

Figure 65c
Pilot Tapered
Glenosphere Inserter

Glenosphere Locking Screw as a guide to the central hole and to ensure it is properly aligned relative to the bone cage. When the glenosphere is fully seated, drive the screw until it locks the assembly together (*Figure 65b*).

Pilot Tapered Glenosphere Inserter: Attach the T-Handle to the inserter. Align the T-Handle in the north/south axis of the glenosphere to ensure that it is properly oriented with the Glenoid Plate. The pilot tip fits into the baseplate to aid in orienting the glenosphere onto the baseplate. Once the glenosphere is seated on the baseplate, apply digital pressure to ensure the glenosphere stays on the baseplate and remove the inserter. Do not attempt to impact the Pilot Glenosphere Inserter once the glenosphere is seated (*Figure 65c*).

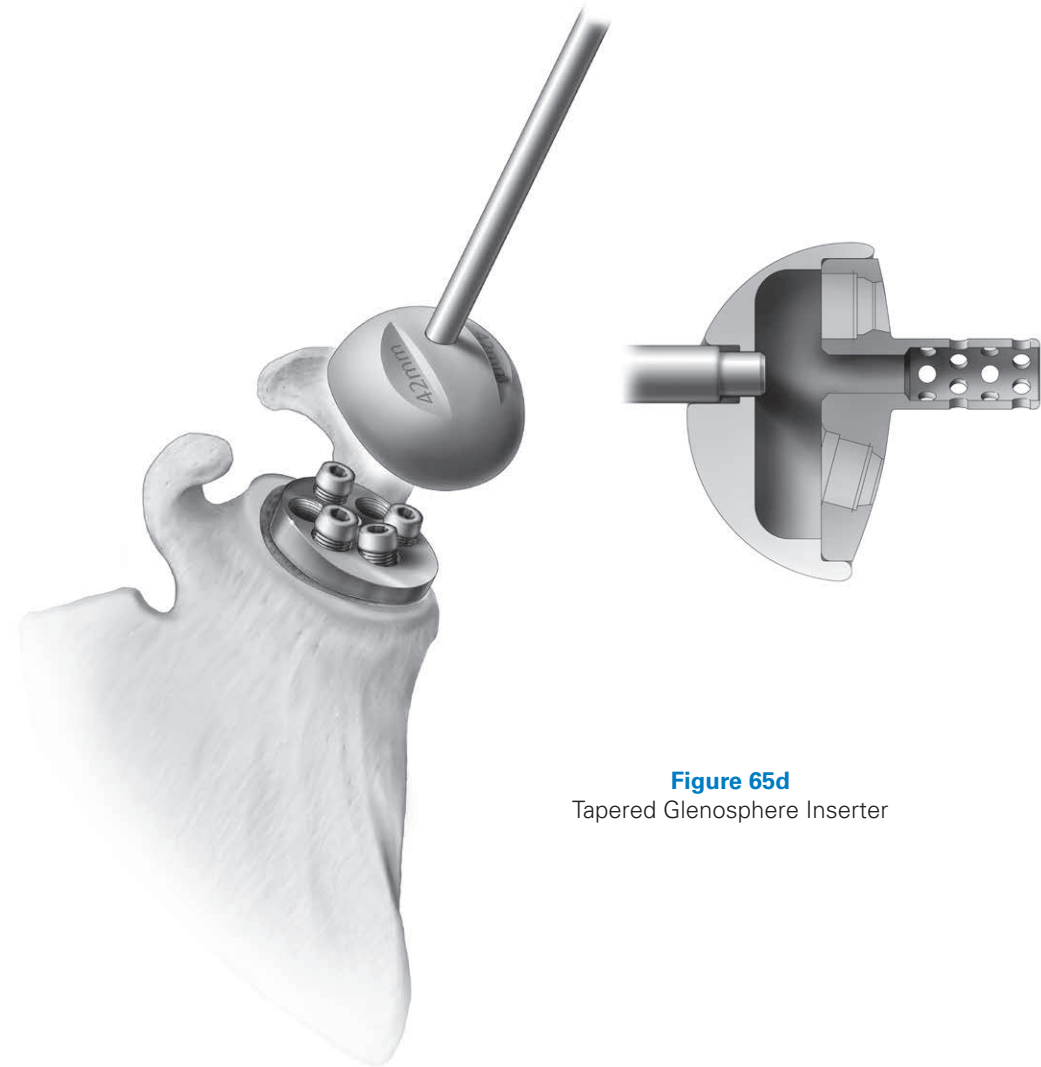

Figure 65d
Tapered Glenosphere Inserter

The Tapered Glenosphere Inserter: Attach the Tapered Glenosphere Inserter in the same manner as the Pilot Glenosphere Inserter. This instrument provides rotational stability and axial control. Since the instrument is cannulated, a 0.062 inch guide wire or K-wire can be inserted into the bone cage of the Glenoid Plate to aid with insertion (*Figure 65d*).

Finally, the Glenosphere Trial is connected to the Glenoid Plate with the Glenosphere Locking Screw to prevent the Glenosphere from disengaging during trial reductions.

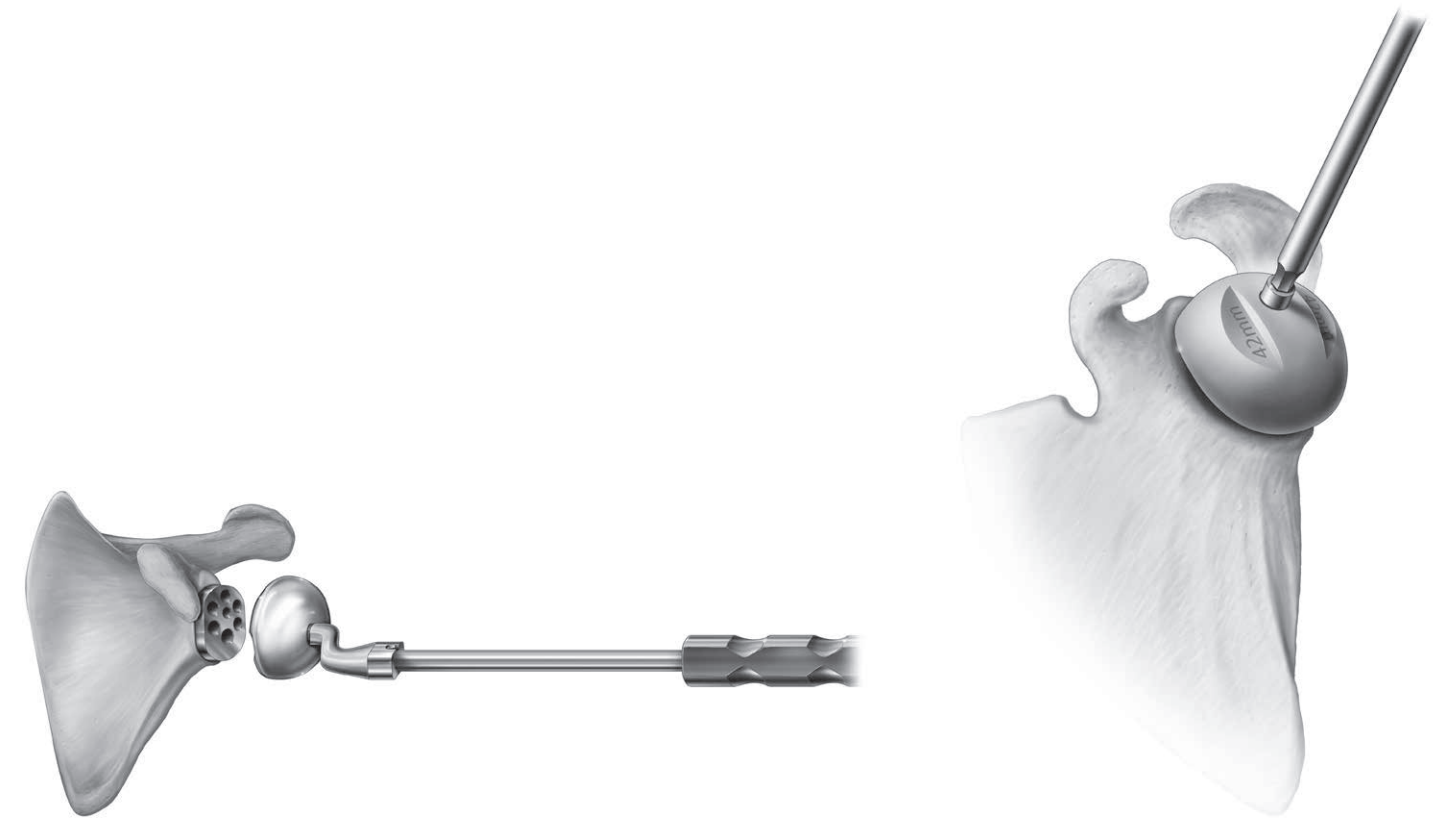

Figure 65e
Klimo Glenosphere Inserter

Figure 66
Glenosphere Locking Screw

Attach the Klimo Inserter to the impactor handle (*Figure 65e*). The curved axis of the inserter (the elbow of the inserter) should be aligned at the three o'clock position for a right shoulder or the nine o'clock position for the left shoulder. For rotational stability and axial control, a mallet can be used to engage the inserter on the glenosphere by striking the top of the impactor handle. The Klimo Inserter helps to keep the glenosphere aligned with the long axis of the Glenoid Plate during insertion. Do not attempt to impact the Klimo Inserter once the glenosphere is seated.

SURGICAL TIP
The Glenosphere Locking Screw is placed perpendicular to the hole within the Glenosphere and the Glenoid Baseplate, which are aligned with one another. Note that the outer periphery of the apical hole of the Glenosphere is curved because of the intersection of the articular curvature on the superior surface of the device. The Glenosphere Locking Screw should not be inserted perpendicular to this articular curvature but instead be inserted perpendicular to the Baseplate and hole within the Glenosphere (*Figure 66*).



Figure 67
Humeral Tray Trial



Figure 68
Humeral Tray Trial and
Liner Trial



Figure 69
Liner Trial Removal

STEP 5: TRIALING THE HUMERAL ADAPTER TRAY AND LINER

The +0mm **Humeral Adapter Tray Trial** is attached to the humeral stem by threading the **Humeral Adapter Tray Captured Screw** into the Humeral Stem's screw hole (*Figure 67*) (+10mm is also attached this way).

SURGICAL TIP

It is critical that the **Humeral Adapter Tray** be oriented such that the line on the Adapter Tray aligns with the lateral fin of the Humeral Stem.

The +5mm trial tray can be added as needed. For a +10mm offset and greater, remove the +0mm Humeral Adapter Tray Trial and insert the +10mm tray trial. To obtain a +15mm offset (special order) and larger, the +5mm tray trial will need to be added. Combinations of trays and liners can achieve the following offsets: +0, +2.5, +5.0, +7.5, +10.0, +12.5mm and available by special order +15 and +17.5mm. It is important to note that the assembled humeral component will have a humeral neck angle of 145 degrees because the liner adds 12.5 degrees to the stem's 132.5 degree neck angle (*Figure 68*).

To insert the **Humeral Liner Trial** into the Trial Tray, the underside asymmetric-connecting feature should be appropriately aligned and the liner/tray trials should be pressed together until the C-spring engages. To disengage the trials, the tip of the **Humeral Liner Removal Tool** is inserted into the recessed region of the trial tray and the instrument is turned like a key until the spring that connects the Humeral Liner Trials and plate trials is disengaged, thereby freeing the Liner (*Figure 69*).

The stability of the implant is assessed during a trial reduction. The shoulder should be placed through a range of motion to assess the stability of the construct. While each surgeon may have their own system to assess stability, we approach the trial reduction as follows:

- 1) With reduction and arm by the side, the lateral deltoid and conjoined tendon should be under tension. The expectation is that the reduction should require more distraction to achieve than reduction of non-constrained implants.
- 2) Forward elevation and abduction should be assessed to determine that the construct is stable and the components do not impinge on bony structures.
- 3) Internal and external rotation should be assessed with the humerus at 0 and 90 degrees to assess stability. Although maximal ranges of external rotation may produce some impingement posteriorly, it should not result in instability.
- 4) With the arm at the side, there should be no evidence of impingement that results in distraction of the implants.



Figure 70
Insert Definitive Glenosphere
and Screw

If additional stability is required based upon the trial reduction, constrained liner options are provided in the same offset as the standard liners. While constrained liners will provide better stability, it is important to note they will also reduce the potential range of motion that can be achieved. If tension is inadequate, additional offset can be added up to 12.5mm. If trial components are changed, additional closed reductions and assessments should be performed to confirm that the desired stability has been obtained. In the unusual situation in which the +0mm liner is too tight, the humeral component should be removed and additional bone should be resected using the methods described.

STEP 6: INSERTING THE FINAL IMPLANTS

The Humeral Liner Trial, Humeral Adapter Tray Trial and Glenosphere Trial are removed. The final Glenosphere is

implanted in the same manner used with the Glenosphere Trial. Impaction of the Glenosphere is not necessary since it is not a Morse taper. The Glenosphere is secured with the Glenosphere Locking Screw, which employs a Spiralock® technology (Figure 70).

SURGICAL TIP

If you hear the Glenosphere Locking Screw “squeaking” prior to the screw head being recessed in the Glenosphere apical hole—STOP. The Glenosphere is not seated on the baseplate correctly. Run an instrument along the backside of the Glenosphere to feel for the plate. You should not feel any of the plate if the Glenosphere is seated properly. You can also visually assess this anteriorly.



Figure 71
Cement Definitive Stem

The arm should be placed in extension and the Primary Stem Inserter should be attached to the humeral stem. The stem can now be removed in order to prepare for cementing the stem. **Downsizing the definitive stem from the trial will result in a 1.5mm proximal cement mantle and a 2mm distal cement mantle. Alternatively, the proximal humerus can be broached one size larger than the trial stem (the broaches are tapered distally to allow this technique) and the same size stem can be used as the trial. This provides for a 1.5mm proximal cement mantle and a line-to-line fit distally.** In the majority of cases, the proximal humerus will tolerate broaching an additional size to accommodate the cement mantle (i.e., if an 11mm stem was used, then a 13mm Broach should be inserted to prepare for cementing). However, the Broach must not be forced if there is not adequate proximal humerus to fully seat the larger broach. Adequate stability can still be obtained with a minimal



OR



Figure 72
Lock Torque
Defining Screw

cementation technique. Cementing of the stem should proceed based upon the surgeon’s preferred technique (Figure 71). The Stem Inserter should be used with the stem impacted into place until it is at the level of the bony surface.

The final Humeral Adapter Tray is attached to the Humeral Stem using the **Reverse Torque Defining Screw** (Figure 72).

SURGICAL TIP

It can be helpful to place the Torque Defining Screw through the humeral tray before connecting it to the stem so that the threads engage more easily. Impact the T-handle with a Mallet to ensure the driver is fully engaged in the screw. Failure to fully engage the UHMWPE plug on the screw head may prevent the screw head from being retained by the torque defining screw driver.

DETAILED OPERATIVE TECHNIQUE

INSERTING THE FINAL IMPLANTS

Size	Color of Impactor Tips
38	Blue
42	Yellow
46	Orange

TABLE 7
Impactor Tips

It is critical that the Humeral Adapter Tray be oriented properly, which requires aligning the indicator mark on the tray with the lateral fin on the stem. The plate is locked to the stem by applying 11 N·m torque to the Screw with the supplied driver while countering the torque to the arm with the **Reverse Shoulder Modular Replicator Handle**. The superior portion of the Screw will disengage when 11 N·m is reached (and will remain in the Screw Drive, both of which are disposable). After the head of the Torque Defining Screw disengages at 11 N·m, verify that the screw head is retained by the Torque Defining Screw Driver.

The final Humeral Liner is attached to the Humeral Adapter Tray by orienting the asymmetric connecting features **and sliding the lip of the liner under the superior rim of the Humeral Tray**.

SURGICAL TIP

The big lip of the poly should be inferior with the Equinox Reverse. As noted on the previous page, it can also be helpful to place the Torque Defining Screw through the humeral tray before connecting it to the stem so that the threads engage more easily.

As with the trial insertion, it is important to note that the assembled humeral component will have a humeral neck angle of 145 degrees because the Humeral Liner adds 12.5 degrees to the stem's 132.5-degree neck angle. Finally, the apical mushroom of the Humeral Liner is engaged to the apical lock of the Humeral Adapter Tray by impacting the Humeral Liner with the appropriately sized **Humeral Liner Impactor Tip** (Table 7).

DETAILED OPERATIVE TECHNIQUE

DELTOPECTORAL CLOSURE

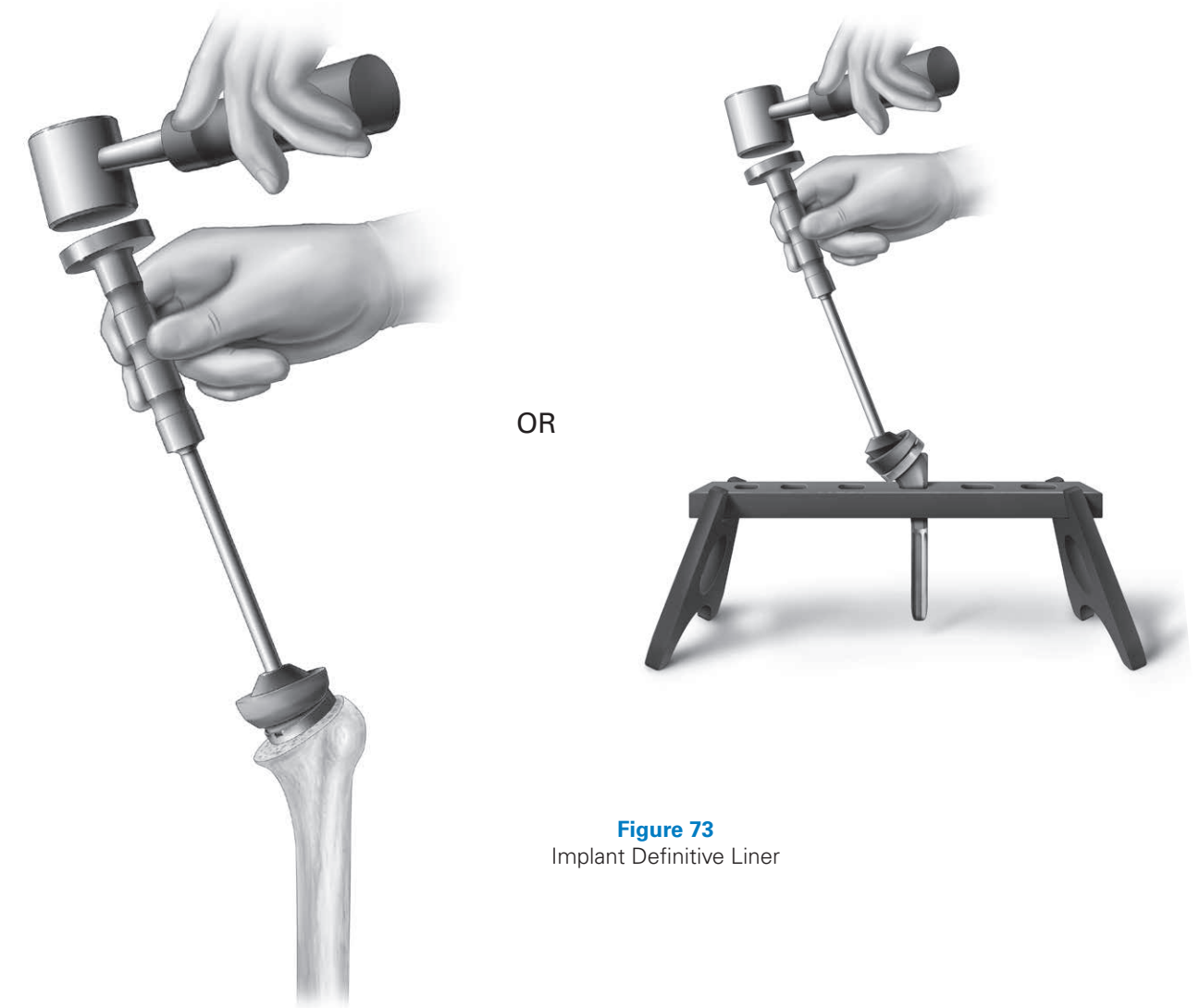

Figure 73
Implant Definitive Liner

The humeral liner should be impacted until it sits flush on the Humeral Adapter Tray (Figure 73). At this point, the humeral component should be reduced onto the Glenosphere. Range of motion and stability should be assessed to confirm the findings from the trial reduction. Once this assessment has been made, closure can be performed.

Alternatively, the stem, tray and liner can be assembled using the Back Table Assembly Stand first and then placed as a unit into the humerus with cement. The disadvantage of this technique is that further implant trialing is not possible, so it should only be used when the surgeon is confident about the thickness of the tray and liners based on the previous trialing. The advantage of this technique is that the shoulder can be reduced and the surgeon can begin closing while the cement is hardening.

STEP 7: DELTOPECTORAL CLOSURE

If the subscapularis tendon was divided during the approach it should be reattached at this time. The method of reattachment is based upon surgeon preference and is generally determined by the method of tenotomy performed. The repair will be either tendon-to-tendon or tendon-to-bone using #2 heavy non-absorbable sutures. We prefer the use of a drain because of the relatively large dead-space and the potential for hematoma formation. The use of a drain will limit the risk of hematoma formation. The deltopectoral interval is closed followed by closure of the subcutaneous tissue and the skin. The upper extremity is then placed in a sling and swathe.



Figure 74
Remove Glenosphere

STEP 8: SUPEROLATERAL CLOSURE

A drain should be inserted to minimize the risk of post-operative hematoma formation. The anterior deltoid should be repaired directly to the anterior acromion with #2 non-absorbable sutures passed through drill holes. The split between the anterior and middle deltoid should be repaired with absorbable sutures. The subcutaneous tissue layer is then closed, followed by the skin closure. The upper extremity is then placed in a sling and swathe.

Radiographs are usually obtained in the operating room to document the position and alignment of the implants. The specific views obtained are based upon surgeon preference.

Glenosphere Removal

If the Glenosphere needs to be removed, the removal instrument can be used to hook into the anterior and posterior recesses on the underside of the Glenosphere to lever it off of the baseplate (*Figure 74*).

Post-Operative Rehabilitation

The rehabilitation program can be carefully started on the same day as surgery or by postoperative day one. All patients should begin active range of motion of the elbow, wrist and hand. Range of motion of the shoulder consists of passive forward elevation, external rotation based on the intra-operative assessment and internal rotation to the chest wall.

Isometric deltoid strengthening can also be started on post-operative day one. Patients should be instructed to perform these exercises five to six times per day for short periods of up to 10 minutes each session.

Some surgeons may prefer to treat the patient in a sling with no shoulder rehabilitation for a period of three to four weeks. **It is very important that caregivers do not pull up on the operated arm of the patient in an effort to assist the patient from bed or a chair as this might cause dislocation.**

The sling is discontinued after six weeks. A longer period of sling use is indicated if there is concern about the stability of the joint. When the sling is discontinued, active and active-assisted range of motion should begin. Internal rotation behind the back can also be started at this time. Isometric internal and external rotation is added at six weeks and gentle resistive strengthening of the deltoid and rotator cuff begins 10-12 weeks postoperatively. When the sling is removed, the patient is instructed to increase use of the upper extremity for activities of daily living.

IMPLANT LISTING

CATALOG NO.	PART DESCRIPTION
300-01-07	Humeral Stem, Primary, Press-Fit, 7mm
300-01-09	Humeral Stem, Primary, Press-Fit, 9mm
300-01-11	Humeral Stem, Primary, Press-Fit, 11mm
300-01-13	Humeral Stem, Primary, Press-Fit, 13mm
300-01-15	Humeral Stem, Primary, Press-Fit, 15mm
300-01-17	Humeral Stem, Primary, Press-Fit, 17mm
306-01-08	Humeral Long Stem, 8x175mm
306-02-08	Humeral Long Stem, 8x215mm
306-02-10*	Humeral Long Stem, 10x200mm
306-02-12*	Humeral Long Stem, 12x200mm
300-10-15	Anatomic Replicator Plate, 1.5mm o/s
300-10-45	Anatomic Replicator Plate, 4.5mm o/s
300-20-02	Torque Defining Screw Kit
310-01-38	Humeral Head, Short, 38mm
310-01-41	Humeral Head, Short, 41mm
310-01-44	Humeral Head, Short, 44mm
310-01-47	Humeral Head, Short, 47mm
310-01-50	Humeral Head, Short, 50mm
310-01-53	Humeral Head, Short, 53mm
310-02-38	Humeral Head, Tall, 38mm
310-02-41	Humeral Head, Tall, 41mm
310-02-44	Humeral Head, Tall, 44mm
310-02-47	Humeral Head, Tall, 47mm
310-02-50	Humeral Head, Tall, 50mm
310-02-53	Humeral Head, Tall, 53mm
310-03-47	Humeral Head, Expanded, 47mm
310-03-50	Humeral Head, Expanded, 50mm
310-03-53	Humeral Head, Expanded, 53mm
314-01-02	Glenoid, Keeled, Alpha, Small
314-01-03	Glenoid, Keeled, Alpha, Medium
314-01-04	Glenoid, Keeled, Alpha, Large
314-01-13	Glenoid, Keeled, Beta, Medium
314-01-14	Glenoid, Keeled, Beta, Large
314-02-02	Glenoid, Pegged, Alpha, Small
314-02-03	Glenoid, Pegged, Alpha, Medium
314-02-04	Glenoid, Pegged, Alpha, Large
314-02-13	Glenoid, Pegged, Beta, Medium
314-02-14	Glenoid, Pegged, Beta, Large
314-02-15	Glenoid, Pegged, Beta, Extra Large

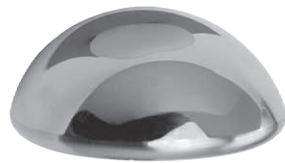

CATALOG NO.	PART DESCRIPTION
314-13-02	Glenoid, Cage, Alpha, Small
314-13-03	Glenoid, Cage, Alpha, Medium
314-13-04	Glenoid, Cage, Alpha, Large
314-13-13	Glenoid, Cage, Beta, Medium
314-13-14	Glenoid, Cage, Beta, Large
314-13-15	Glenoid, Cage, Beta, Extra Large



CATALOG NO.	PART DESCRIPTION
320-10-00	Humeral Adapter Tray, +0
320-10-05	Humeral Adapter Tray, +5
320-10-10	Humeral Adapter Tray, +10
320-10-15*	Humeral Adapter Tray, +15



CATALOG NO.	PART DESCRIPTION
320-38-00	Humeral Liner, 38mm, +0
320-38-03	Humeral Liner, 38mm, +2.5
320-38-10	Constrained Humeral Liner, 38mm, +0
320-38-13	Constrained Humeral Liner, 38mm, +2.5
320-42-00	Humeral Liner, 42mm, +0
320-42-03	Humeral Liner, 42mm, +2.5
320-42-10	Constrained Humeral Liner, 42mm, +0
320-42-13	Constrained Humeral Liner, 42mm, +2.5
320-46-00	Humeral Liner, 46mm, +0*
320-46-03	Humeral Liner, 46mm, +2.5*
320-46-10	Constrained Humeral Liner, 46mm, +0*
320-46-13	Constrained Humeral Liner, 46mm, +2.5*



CATALOG NO.	PART DESCRIPTION
320-20-18	Compression Screw/Locking Cap Kit, 4.5 x 18mm, White
320-20-22	Compression Screw/Locking Cap Kit, 4.5 x 22mm, Black
320-20-26	Compression Screw/Locking Cap Kit, 4.5 x 26mm, Orange
320-20-30	Compression Screw/Locking Cap Kit, 4.5 x 30mm, Blue
320-20-34	Compression Screw/Locking Cap Kit, 4.5 x 34mm, Red
320-20-38	Compression Screw/Locking Cap Kit, 4.5 x 38mm, Green
320-20-42	Compression Screw/Locking Cap Kit, 4.5 x 42mm, Yellow
320-20-46	Compression Screw/Locking Cap Kit, 4.5 x 46mm, Purple



CATALOG NO.	PART DESCRIPTION
320-01-38	Glenosphere, 38mm
320-01-42	Glenosphere, 42mm
320-01-46	Glenosphere, 46mm*



CATALOG NO.	PART DESCRIPTION
320-15-05	Glenosphere Locking Screw



CATALOG NO.	PART DESCRIPTION
320-15-01	Glenoid Plate



CATALOG NO.	PART DESCRIPTION
320-20-00	Reverse Shoulder, Torque Defining Screw Kit



INSTRUMENT LISTING

CATALOG NO. PART DESCRIPTION

301-01-07 Broach, 7mm
 301-01-09 Broach, 9mm
 301-01-11 Broach, 11mm
 301-01-13 Broach, 13mm
 301-01-15 Broach, 15mm

301-03-01 Modular Broach Handle

301-03-10 Retroversion Handle

301-07-01 Mallet

301-07-10 Primary Stem Inserter/Extractor

301-07-20 Stem Protector

301-07-30 T-Handle

301-07-50 Screw Drive Handle

301-07-60 Small Stem Protector

301-07-70 T-Handle, Short

301-07-80 Screw Drive Handle, Ratcheting



CATALOG NO. PART DESCRIPTION

301-10-10 Torque Defining Removal Instrument

301-10-00 Modular Anatomic Replicator Handle

301-10-35 Modular Anatomic Replicator Fork

311-01-01 Anatomic Osteotomy Guide

311-01-10 132.5 Degree Osteotomy Guide

311-01-20 Humeral Head Sizer

311-05-01 Head Removal Tool

The below catalog numbers are available in multiple sizes. To order, replace "XX" with the desired size:

301-15-XX Straight Reamer, Multiple Sizes

301-10-XX Plate Dial, Multiple Sizes

311-01-XX Short Head Trial, Multiple Sizes
 311-02-XX Tall Head Trial, Multiple Sizes
 311-03-XX Expanded Head Trial, Multiple Sizes

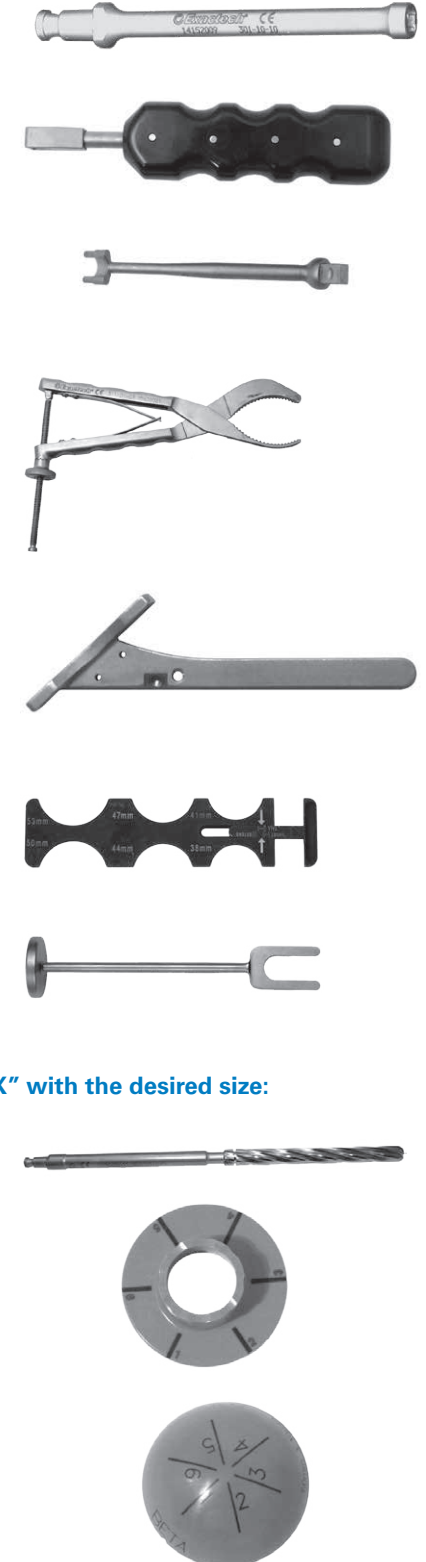

INSTRUMENT LISTING

CATALOG NO. PART DESCRIPTION

311-07-05 Impactor

311-07-07 Humeral Head Impactor Tip

315-07-06 Glenoid Impactor Tip

315-01-02 Keel Trial
315-01-03 Keel Trial
315-01-04 Keel Trial

315-07-30 Central Holding Pin

315-07-40 Holding Pin, Multiple Sizes Keel

315-09-05 Keeled Cement Pressurizer

315-09-06 Pegged Cement Pressurizer

315-09-08 Pegged Cement Pressurizer Peripheral Peg

315-12-02 Peg Trial, Small
315-12-03 Peg Trial, Medium
315-12-04 Peg Trial, Large
315-12-05 Peg Trial, Extra Large

315-25-00 Modular Cannulated TriDrive

315-25-11 Modular Primary Pilot-Tip Reamer, Extra Small
315-25-12 Modular Primary Pilot-Tip Reamer, Small
315-25-13 Modular Primary Pilot-Tip Reamer, Medium
315-25-14 Modular Primary Pilot-Tip Reamer, Large
315-25-15 Modular Primary Pilot-Tip Reamer, Extra Large



CATALOG NO. PART DESCRIPTION

315-26-01 Cage Glenoid Depth Gauge

315-30-02 Alpha Spider Glenoid Reamer/Inserter Tip, Small
315-30-03 Alpha Spider Glenoid Reamer/Inserter Tip, Medium
315-30-04 Alpha Spider Glenoid Reamer/Inserter Tip, Large

315-30-13 Beta Spider Glenoid Inserter/Impactor Tip, Medium
315-30-14 Beta Spider Glenoid Inserter/Impactor Tip, Large
315-30-15 Beta Spider Glenoid Inserter/Impactor Tip, Extra Large

315-27-02 Center Hole Peg Drill Guide, Left
315-27-03 Center Hole Peg Drill Guide, Right

315-27-04 Peripheral Hole Peg Drill Guide, Left
315-27-05 Peripheral Hole Peg Drill Guide, Right

























315-27-06 Keel Drill Guide

315-27-17 Modular Peripheral Cage Peg Extractor

315-27-18 Modular Central Peg Extractor



INSTRUMENT LISTING

CATALOG NO.	PART DESCRIPTION		CATALOG NO.	PART DESCRIPTION	
315-27-40	Peripheral Peg Drill Guide Holding Pin		317-01-08	Wolfe Retractor	
315-27-60	Modular Center Peg/Keel Drill		317-20-01	Forked (Playboy) Retractor – Small	
315-27-61	Modular Short Keel Drill		317-20-03	Deltoid Retractor	
315-27-62	Modular Peripheral Peg Drill		321-01-07	7mm Humeral Stem Trial	
315-27-63	Modular Cannulated Center Peg Drill		321-01-09	9mm Humeral Stem Trial	
			321-01-11	11mm Humeral Stem Trial	
			321-01-13	13mm Humeral Stem Trial	
			321-01-15	15mm Humeral Stem Trial	
			321-01-17	17mm Humeral Stem Trial	
315-35-11	Modular Primary Cannulated Reamer, Extra Small		321-01-25	Glenosphere Inserter	
315-35-12	Modular Primary Cannulated Reamer, Small		321-01-26	Pilot Glenosphere Inserter	
315-35-13	Modular Primary Cannulated Reamer, Medium		321-01-27	Glenosphere Inserter Slide	
315-35-14	Modular Primary Cannulated Reamer, Large		321-01-28	Glenosphere Inserter Spring Handle	
315-35-15	Modular Primary Cannulated Reamer, Extra Large		321-01-29	Universal Glenosphere Inserter Clamp	
317-01-02	Humeral Head Retractor		321-01-31	Klimo Inserter	
317-01-03	Darrach Retractor		321-02-15	Glenosphere Removal Hook	
317-01-04	Dual Point Glenoid Retractor		321-01-38	Glenosphere Trial, 38mm	
317-01-05	Single Point Glenoid Retractor		321-01-42	Glenosphere Trial, 42mm	
			321-01-46	Glenosphere Trial, 46mm*	
317-01-06	Hohmann Retractor		321-07-05	Impactor Handle	

INSTRUMENT LISTING

CATALOG NO. PART DESCRIPTION

321-07-10	Glenoid Plate Coring Reamer
321-07-38	Humeral Liner Impactor Tip, 38mm
321-07-42	Humeral Liner Impactor Tip, 42mm
321-07-46	Humeral Liner Impactor Tip, 46mm*
321-10-00	Humeral Adapter Tray Trial Assembly, +0
321-10-01	Humeral Adapter Tray Captured Screw
321-10-05	Humeral Adapter Tray Trial Assembly, +5
321-10-11	Humeral Adapter Tray Trial Assembly, +10
321-10-35	Reverse Shoulder Modular Replicator Handle
321-15-04	Adjustable Angle Drill Guide
321-20-00	Drill Bit Kit, 2.0mm and 3.2mm
321-15-08	Hex Screwdriver, 3.5mm
321-15-09	Glenoid Screw Depth Gauge
321-15-11	Humeral Liner Removal Tool



CATALOG NO. PART DESCRIPTION

321-15-13	Glenoid Plate Inserter/Impactor
321-15-22	Back Table Assembly
321-15-23	Primary Backtable Insert
321-15-30	Modular Glenoid Plate Drill Guide, Superior Lateral, Left
321-15-31	Modular Glenoid Plate Drill Guide, Superior Lateral, Right
321-15-32	Modular Glenoid Plate Drill Guide, Deltpectoral, Left
321-15-33	Modular Glenoid Plate Drill Guide, Deltpectoral, Right
321-25-01	Modular Reverse Pilot-Tip Starter Reamer
321-25-38	Modular Reverse Pilot-Tip Reamer, 38mm
321-25-42	Modular Reverse Pilot-Tip Reamer, 42mm
321-25-46	Modular Reverse Pilot-Tip Reamer, 46mm*
321-35-01	Modular Reverse Cannulated Starter Reamer
321-35-38	Modular Reverse Cannulated Reamer, 38mm
321-35-42	Modular Reverse Cannulated Reamer, 42mm
321-35-46	Modular Reverse Cannulated Reamer, 46mm*
321-38-00	Humeral Liner Trial, +0, 38mm
321-38-03	Humeral Liner Trial, +2.5, 38mm
321-38-10	Humeral Liner Trial, Constrained, +0, 38mm
321-38-13	Humeral Liner Trial, Constrained, +2.5, 38mm
321-42-00	Humeral Liner Trial, +0, 42mm
321-42-03	Humeral Liner Trial, +2.5, 42mm
321-42-10	Humeral Liner Trial, Constrained, +0, 42mm
321-42-13	Humeral Liner Trial, Constrained, +2.5, 42mm
321-46-00	Humeral Liner Trial, +0, 46mm*
321-46-03	Humeral Liner Trial, +2.5, 46mm*
321-46-10	Humeral Liner Trial, Constrained, +0, 46mm*
321-46-13	Humeral Liner Trial, Constrained, +2.5, 46mm*



SYSTEM SPECIFICATIONS

(ALL DIMENSIONS IN MILLIMETERS)

HUMERAL STEM

Distal Diameter	Length*	Inherent Medial Offset	Material	Surface Finish		Geometry	
				Proximal	Distal	Proximal	Distal
7	100	7.5	Ti-6Al-4V	16 grade grit blast	Hi-Brite Polish	Trapezoidal	Cylindrical with Flutes
9	105						
11	110	8.5					
13	115						
15	120						
17	125	9.5					

*Measured from distal tip to center of proximal spherical bore

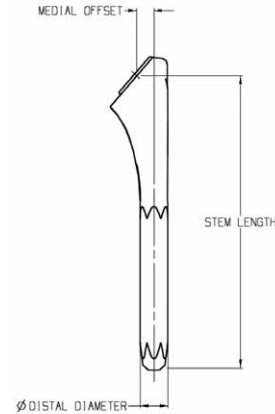

REPLICATOR PLATES

Offset	Material	Offset Ranges*		Angle Ranges (°)	
		Med/Lat	Ant/Post	Inclination	Version
1.5	Ti-6Al-4V	0-14	0-6	125-140	+/-7.5
4.5					

*Includes effect of head offsets

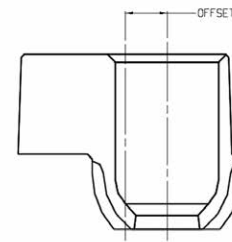

HUMERAL HEADS

Diameter	Height			Offset	Glenoid		Material
	Short	Tall	Expanded		Mate		
38	16	19		0	Alpha	Co-Cr	
41	16	20		0			
44	17	21		1.5			
47	18	22	26	1.5	Beta		
50	19	23	27	1.5			
53	20	24	28	1.5			

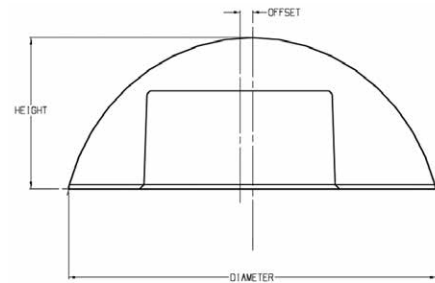

GLENOIDS

Sizes	Fixation	Material	Radial Mismatch	Shape
Small Medium Large	Cage, Peg, or Keel	Compression Molded UHMWPE	Mean: 5.5	Anatomic (Pear)
Extra Large	Cage, Peg			

SYSTEM SPECIFICATIONS

(ALL DIMENSIONS IN MILLIMETERS)

HUMERAL LINER/HUMERAL TRAY OFFSET COMPARISONS

	+0mm Humeral Liners (Standard and Constrained)	+2.5mm Humeral Liners (Standard and Constrained)
+0 Humeral Tray	0	2.5
+5 Humeral Tray	5	7.5
+10 Humeral Tray	10	12.5
+15 Humeral Tray*	15	17.5

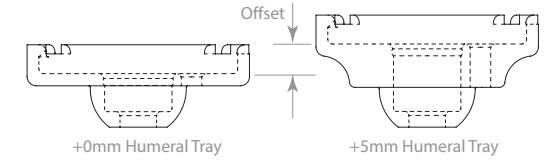

HUMERAL LINER DEPTH COMPARISONS

	Standard Liner Depth (+0mm and +2.5mm)	Constrained Liner Depth (+0mm and +2.5mm)
38 Humeral Liners	8.5	12.0
42 Humeral Liners	8.8	12.6
46 Humeral Liners*	8.9	13.1

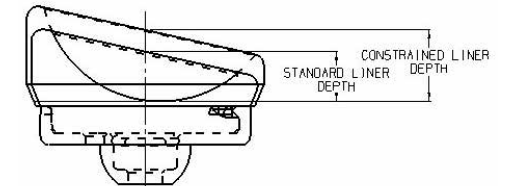

COMPRESSION SCREWS

Outer Diameter	Length	Color
4.5	18	White
	22	Black
	26	Orange
	30	Blue
	34	Red
	38	Green
	42	Yellow
	46	Purple

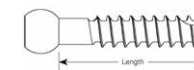

GLENOSPHERE/GLENOID PLATE

	Diameter	Thickness	Average Lateralization of Center of Rotation
38 Glenosphere	38	23.1	2
42 Glenosphere	42	25.1	
46 Glenosphere*	46	27.1	

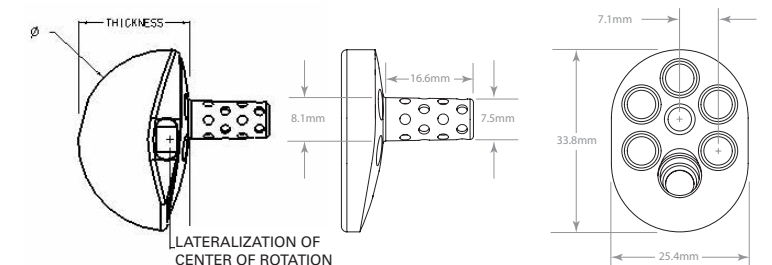

INDICATIONS FOR USE

PRIMARY & REVERSE SHOULDER SYSTEM

INDICATIONS

The Equinoxe Shoulder System is indicated for use in skeletally mature individuals with degenerative diseases or fractures of the glenohumeral joint where total or hemiarthroplasty is determined by the surgeon to be the preferred method of treatment.

- The cemented primary humeral stem, long/revision stem, fracture stems and all Equinoxe glenoids are intended for cemented fixation.
- The press-fit humeral stems are intended for press-fit applications but may be used with bone cement at the discretion of the surgeon.
- The reverse humeral components are intended to be used in cemented applications or in revision cases when the humeral component is well-fixed/stable, as deemed by the orthopaedic surgeon.
- Humeral Heads are intended for use in cemented and press-fit applications.

Clinical indications for the PRIMARY (P), LONG/REVISION (L/R) and FRACTURE (F) humeral components are as follows:

P	L/R	F	Indications
√	√	√	Rheumatoid Arthritis, Osteoarthritis, Osteonecrosis Or Post-Traumatic Degenerative Problems
√	√		Congenital Abnormalities In The Skeletally Mature
√			Primary And Secondary Necrosis Of The Humeral Head
√		√	Humeral Head Fracture With Displacement Of The Tuberosities
√	√		Pathologies Where Arthrodesis Or Resectional Arthroplasty Of The Humeral Head Are Not Acceptable
√	√		Revisions Of Humeral Prostheses When Other Treatments Or Devices Have Failed (Where Adequate Fixation Can Be Achieved)
		√	Displaced Three-Part And Four-Part Upper Humeral Fractures
	√		Spiral And Other Fractures Of The Mid-Humerus (In Combination With Glenohumeral Degenerative Diseases)
	√		Revision Of Failed Previous Reconstructions When Distal Anchorage Is Required
√	√		To Restore Mobility From Previous Procedures (E.g. Previous Fusion)

The Equinoxe Reverse Shoulder System is indicated for use in skeletally mature individuals with degenerative diseases of the glenohumeral joint and a grossly deficient, irreparable rotator cuff. The Equinoxe Reverse Shoulder is also indicated for a failed glenohumeral joint replacement with loss of rotator cuff function resulting in superior migration of the humeral head.

CONTRAINDICATIONS

Use of the Equinoxe Shoulder System is contraindicated in the following situations:

- Osteomyelitis of the proximal humerus or scapula; if a systemic infection or a secondary remote infection is suspected or confirmed, implantation should be delayed until infection is resolved.
- Inadequate or malformed bone that precludes adequate support or fixation of the prosthesis.
- Neuromuscular disorders that do not allow control of the joint.
- Significant injury to the brachial plexus.
- Non-functional deltoid muscles.
- Patient's age, weight, or activity level would cause the surgeon to expect early failure of the system.
- The patient is unwilling or unable to comply with the post-operative care instructions.
- Alcohol, drug, or other substance abuse.
- Any disease state that could adversely affect the function or longevity of the implant.

NOTES

REFERENCES

1. **Roche C, et al.** Geometric analysis of the Grammont reverse shoulder prosthesis: an evaluation of the relationship between prosthetic design parameters and clinical failure modes. Proceedings of the 19th Annual Congress of the International Society for Technology in arthroplasty; 2006 Oct 6-9; New York, NY.
2. **Roche C, et al.** An evaluation of the relationships between reverse shoulder design parameters and range of motion, impingement, and stability. *J Shoulder Elbow Surg.* 2009 Sep-Oct; 18(5):734-41.
3. **Roche C, et al.** Effect of varying screw configuration and bone density on reverse shoulder glenoid fixation following cyclic loading. Transactions of the 54th Annual Orthopaedic Research Society Meeting; 2008 Mar 2-5; San Francisco, CA.

Exactech is proud to have offices and distributors around the globe. For more information about Exactech products available in your country, please visit www.exac.com

For additional device information, refer to the Exactech Shoulder System—Instructions for Use for a device description, indications, contraindications, precautions and warnings. For further product information, please contact Customer Service, Exactech, Inc., 2320 NW 66th Court, Gainesville, Florida 32653-1630, USA. (352) 377-1140, (800) 392-2832 or FAX (352) 378-2617.

Exactech, as the manufacturer of this device, does not practice medicine, and is not responsible for recommending the appropriate surgical technique for use on a particular patient. These guidelines are intended to be solely informational and each surgeon must evaluate the appropriateness of these guidelines based on his or her personal medical training and experience. Prior to use of this system, the surgeon should refer to the product package insert for comprehensive warnings, precautions, indications for use, contraindications and adverse effects.

The products discussed herein may be available under different trademarks in different countries. All copyrights, and pending and registered trademarks, are property of Exactech, Inc. This material is intended for the sole use and benefit of the Exactech sales force and physicians. It should not be redistributed, duplicated or disclosed without the express written consent of Exactech, Inc. ©2017 Exactech, Inc. 718-01-30 Rev. J 0417



GLOBAL HEADQUARTERS:
2320 NW 66TH COURT
GAINESVILLE, FL 32653 USA

+1 352.377.1140
+1 800.EXACTECH
+1 352.378.2617 (FAX)
www.exac.com